



875-0395-10

**V200s Vector™
GNSS Compass**

User Guide
Revision: A6
March 22, 2021

Table of Contents

Device Compliance, License and Patents	4
Terms and Definitions	6
Chapter 1: Introduction	8
Overview	8
Product Overview	9
Key Features.....	12
What’s Included in Your Kit.....	13
Using PocketMax to Communicate with the V200s	14
Firmware Upgrades.....	18
Chapter 2: Mounting the V200s	23
Overview	23
Mounting the V200s	24
Surface-mounting the V200s	36
Pole-mounting the V200s	41
Chapter 3: Connecting the V200s	43
Overview	43
Ports	44
Selecting Baud Rates and Message Types	45
Connecting the V200s to External Devices	46
Chapter 4: Understanding the V200s	48
Overview	48
GNSS Overview	49
Differential Operation.....	50
SBAS Tracking.....	51
Atlas L-band	52
Supplemental Sensors.....	53
Time Constants	56
Chapter 5: Operating the V200s	58
Overview	58

Powering the V200s	59
Appendix A: Troubleshooting	60
Overview	60
Troubleshooting.....	61
Appendix B: Technical Specifications.....	64
V200s Technical Specifications	65
Appendix C: Commands and Messages	69
Overview	69
Serial Commands	70
NMEA 0183 Messages	73
Binary Messages	77
Index.....	79
End User License Agreement	80
Warranty Notice.....	84

Device Compliance, License and Patents

Device Compliance

This device complies with part 15 of the FCC Rules. Operation is subject to the following two conditions:
 This device may not cause harmful interference, and
 this device must accept any interference received, including interference that may cause undesired operation.

This product complies with the essential requirements and other relevant provisions of Directive 2014/53/EU. The declaration of conformity may be consulted at [HTTPS://HEMISPHEREGNSS.COM/ABOUT-US/QUALITY-COMMITMENT](https://hemispheregnss.com/about-us/quality-commitment).

E-Mark Statement: This product is not to be used for driverless/autonomous driving.

Copyright Notice

Copyright Hemisphere GNSS, Inc. (2021). All rights reserved.
 No part of this manual may be reproduced, transmitted, transcribed, stored in a retrieval system or translated into any language or computer language, in any form or by any means, electronic, mechanical, magnetic, optical, chemical, manual or otherwise, without the prior written permission of Hemisphere GNSS.

Trademarks

Hemisphere GNSS®, the Hemisphere GNSS logo, TRACER™, Crescent®, Eclipse™, e-Dif®, L-Dif™, PocketMax™, S320™, SBX-4™, Vector™, Vega™, Phantom™, Cygnus™, Atlas™, aRTK, SureFix™, and Athena™ are proprietary trademarks of Hemisphere GNSS, Inc. Other trademarks are the properties of their respective owners.

Patents

Hemisphere GNSS products may be covered by one or more of the following patents:

Patents			
6111549	6876920	7400956	8000381
6397147	7142956	7429952	8018376
6469663	7162348	7437230	8085196
6501346	7277792	7460942	8102325
6539303	7292185	7689354	8138970
6549091	7292186	7808428	8140223
6711501	7373231	7835832	8174437
6744404	7388539	7885745	8184050
6865465	7400294	7948769	8190337
8214111	8217833	8265826	8271194
8307535	8311696	8334804	RE41358

Australia Patents	
2002244539	2002325645
2004320401	

Continued on next page

Device Compliance, License and Patents, Continued

Notice to Customers Contact your local dealer for technical assistance. To find the authorized dealer near you:

Hemisphere GNSS, Inc
8515 East Anderson Drive
Scottsdale, AZ 85255 USA
Phone: (480) 348-6380
Fax: (480) 270-5070
PRECISION@HGNS.COM
[HTTPS://WWW.HEMISPHEREGNSS.COM/](https://www.hemispheregnss.com/)

Technical Support If you need to contact Hemisphere GNSS Technical Support:

Hemisphere GNSS, Inc.
8515 East Anderson Drive
Scottsdale, AZ 85255 USA
Phone: (480) 348-6380
Fax: (480) 270-5070
SUPPORT.HGNS.COM

**Documentation
Feedback**

Hemisphere GNSS is committed to the quality and continuous improvement of our products and services. We urge you to provide Hemisphere GNSS with any feedback regarding this guide by opening a support case at the following website:

[HTTPS://HEMISPHERE.ATLASSIAN.NET/SERVICEDESK/CUSTOMER/PORTAL/2/USER/LOGIN?DESTINATION=PORTAL%2F2](https://hemisphere.atlassian.net/servicedesk/customer/portal/2/user/login?destination=portal%2F2)

Terms and Definitions

Introduction The following table lists the terms and definitions used in this document.

V200s terms & definitions

Term	Definition
Activation	Activation refers to a feature added through a one-time purchase. For features that require recurring fees, see Subscription .
Atlas	Atlas is a subscription-based service provided by Hemisphere GNSS.
BeiDou	BeiDou is a global navigation satellite system deployed and maintained by China.
DGPS/DGNSS	Differential GPS/GNSS refers to a receiver using Differential Corrections.
Differential Corrections	A method of improving precision of a GNSS rover. Two GNSS receivers placed in a nearby area will have similar error. A base station is placed over a known point.
Firmware	Firmware is the software loaded into the receiver that controls the functionality of the receiver and runs the GNSS engine.
Galileo	Galileo is a global navigation satellite system deployed and maintained by the European Union and European Space Agency.
GLONASS	Global Orbiting Navigation Satellite System (GLONASS) is a Global Navigation Satellite System deployed and maintained by Russia.
GNSS	Global Navigation Satellite System (GNSS) is a system that provides autonomous 3D position (latitude, longitude, and altitude) and accurate timing globally by using satellites. Current GNSS providers are: GPS, GLONASS and Galileo.

Continued on next page

Terms and Definitions, Continued

V200s terms & definitions, continued

Term	Definition
GPS	Global Positioning System (GPS) is a global navigation satellite system deployed and maintained by the United States.
Heading	The vector created from the primary to secondary antenna. It points to the direction that the receiver is facing.
I/O	Input/Output
NMEA	National Marine Electronics Association (NMEA) is a marine electronics organization that sets standards for communication between marine electronics.
QZSS	Quasi-Zenith Satellite System (QZSS) is a regional satellite navigation system deployed and maintained by Japan.
RMS	Root mean square
RTK	Real-Time-Kinematic (RTK) is a real-time differential GPS method that provides better accuracy than differential corrections.
SBAS	Satellite Based Augmentation System (SBAS) is a system that provides differential corrections over satellite throughout a wide area or region.
SNR	Signal-to-Noise ratio
Subscription	A subscription is a feature that is enabled for a limited time. Once the end-date of the subscription has been reached, the feature will turn off until the subscription is renewed.
Vector Receiver	A Hemisphere GNSS receiver capable of providing heading.

Chapter 1: Introduction

Overview

Introduction This User Guide provides information to help you quickly set up your V200s Vector GNSS Compass. You can download this manual from the Hemisphere GNSS website at WWW.HGNSS.COM.

Contents

	Topic	See Page
	Product Overview	9
	Key Features	12
	What's Included in Your Kit	13
	Using PocketMax to Communicate with the V200s	14
	Firmware Upgrades	18

Product Overview

Product overview

The V200s Vector™ GNSS Compass is capable of tracking and using GPS, GLONASS, Galileo, BeiDou, and QZSS satellites.

Note: When referring to both the V200s Vector™ GNSS Compass, this manual uses the term V200s.

The multi-GNSS V200s offers an amazing world-wide 30 cm (RMS) accuracy via Hemisphere's Atlas GNSS global correction service.

The V200s offers an incredible combination of simple installation, small form factor, and amazing performance. The compass - measuring only 35 cm in length - mounts easily to a flat surface or pole. The stability and maintenance-free design of the V200s provides simple integration into autopilots, chart plotters, and AIS systems.

There are no mechanical parts such as gimbals or a rotating motor, so the V200s Compass is free from routine maintenance. Heading is determined from GNSS, and there is no need to wait for settling time, gyrocompass calibration and speed corrections. Vector performance is not affected by geomagnetism, making it the perfect solution for any marine application.

The V200s is an integrated system that houses the following:

- Dual mGNSS, multipath-resistant antennas
- Power supply
- Six-axis sensor

The sensor is present to improve system performance and to provide backup heading information in the event a GNSS heading is not available due to signal blockage. The sensor provides a substitute heading, accurate to within 1° per minute for up to three minutes.

Continued on next page

Product Overview, Continued

**Product
overview,
continued**

The V200s's GNSS antennas are separated by 20 cm between phase centers, resulting in a heading performance of better than 0.75° RMS (with High Accuracy Heading activated). The V200s can provide heading and positioning updates of up to 50 Hz and delivers positioning accuracy of 0.6 m 95% of the time when using differential GPS corrections from Satellite Based Augmentation Systems (SBAS) or Atlas.

If you are new to GNSS and SBAS, refer to the [Hemisphere GNSS Technical Reference Manual](#) for further information on these services and technologies before proceeding.



Figure 1-1: V200s GNSS Compass

Continued on next page

Product Overview, Continued

Athena RTK

Athena RTK is Hemisphere's next-generation RTK engine designed to support all available constellations and take advantage of available new signals. Athena was designed to seamlessly integrate into existing product portfolios and supports all major industry correction formats and standards.

Athena RTK can be added to the V200s as an activation.

Athena RTK has the following benefits:

- **Improved Initialization time** - Performing initializations in less than 15 seconds at better than 99.9% of the time.
- **Robustness in difficult operating environments** - Extremely high productivity under the most aggressive of geographic and landscape-oriented environments.
- **Performance on long baselines** - Industry-leading position stability for long baseline applications.

For more information about Athena RTK, see:

[HTTPS://WWW.HEMISPHEREGNSS.COM/TECHNOLOGY/#ATHENA](https://www.hemispheregnss.com/technology/#athena)

Atlas L-band

Atlas L-band is Hemisphere's industry leading correction service, which can be added as a subscription. Atlas L-band has the following benefits:

- **Positioning accuracy** - Competitive positioning accuracies down to 4 cm RMS in certain applications.
- **Positioning sustainability** - Cutting edge position quality maintenance in the absence of correction signals, using Hemisphere's patented technology.
- **Scalable service levels** - Capable of providing virtually any accuracy, precision and repeatability level in the 4 cm to 50 cm range.
- **Convergence time** - Industry-leading convergence times of 10-40 minutes
- **Global Ionospheric Model** - Real-time ionospheric activity and data is sent to the receiver and allows Atlas-capable devices to adjust accordingly, providing excellent convergence performance.

For more information about Atlas L-band, see: [HTTP://HGNS.COM/ATLAS](http://hgns.com/atlas)

Key Features

V200s key features

Key features of the V200s include:

- L1 GPS, GLONASS, Galileo, BeiDou, QZSS
 - 30 cm RMS world-wide positioning accuracy with Atlas corrections
 - Standard 1.5° and optional 0.75° heading accuracy in small form factor
 - Excellent in-band and out-of-band interference rejection
 - Integrated gyro and tilt sensors help deliver fast start-up times and provide heading updates during temporary loss of satellites
 - Provides heading, positioning, heave, pitch, and roll
-

What's Included in Your Kit

V200s kit

Table 1-1 lists the parts included with your V200s. The V200s GNSS Compass and the power/data cable (accessory item) are the only two required components.

Note: The V200s's parts comply with IEC 60945 Section 4.4: "Exposed to the weather."

V200s Parts list

The following table lists the part numbers and description for the V200s.

Table 1-1: V200s Parts list

Part No.	Description
940-3141-11	HGNSS SA V200s SX6
804-0164-20	V200s, SX6, WIFI/BT, HGNSS
940-3152-11	HGNSS SA V200s (OEM - Unbranded)
804-0164-10	V200s, SX6, WIFI/BT, OEM

All the following are accessory items available for purchase separately from your V200s GNSS Compass.

Table 1-2: V200s Accessory list

Part No.	Description
051-0404-10	15 m power/data cable, RA (unterminated)
051-0405-10	15 m power/data cable (unterminated)
710-0162-10	V200 Surface Mounting Kit
710-0166-10	V200 Pole Mounting Kit
710-0167-10	V200 Complete Mounting Kit

Using PocketMax to Communicate with the V200s

Using PocketMax to communicate with the V200s

Hemisphere's PocketMax is a free utility program that runs on your Windows PC or Windows mobile device. Simply connect your Windows device to the V200s via the COM port and open PocketMax.

The screens in PocketMax easily interface with the V200s:

- configure GNSS message output and port settings
- configure the receiver
- record various types of data
- monitor the V200s status and function



PocketMax is available for download from the [Hemisphere GNSS website](#). Use the following steps to set up the V200s communication with PocketMax.

Continued on next page

Using PocketMax to Communicate with the V200s, Continued

Using PocketMax to communicate with the V200s, continued

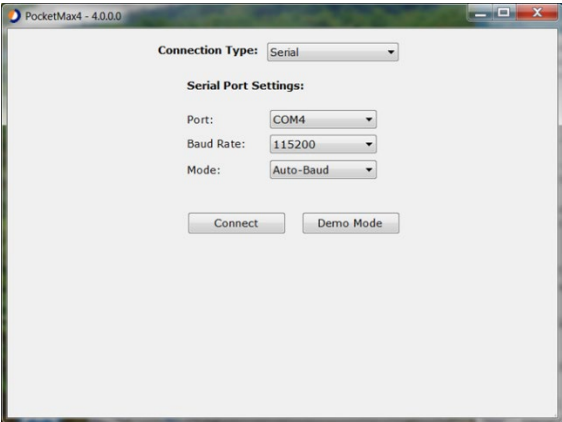
Table 1-3: PocketMax Communication

Step	Action
1	Power on and connect the receiver to your computer's com port. A configuration screen appears prompting you to choose the COM port and baud rate of the receiver.
2	<p>Choose from the following communications settings options:</p> <ul style="list-style-type: none"> • Select COM Port. • If you do not know the baud rate, select the Auto-Baud feature to cycle through all possible baud rates, and click Connect. <div data-bbox="711 869 1269 1287" style="border: 1px solid black; padding: 5px; margin: 10px 0;">  </div> <div data-bbox="711 1329 1269 1743" style="border: 1px solid black; padding: 5px; margin: 10px 0;">  </div>

Continued on next page

Using PocketMax to Communicate with the V200s, Continued

Using PocketMax to communicate with the V200s, continued

Table 1-3: PocketMax Communication (continued)

Step	Action
3	<p>You can monitor your connection status through the message displayed at the bottom of the screen.</p> <p>If you receive a message “Receiver not found...” check your connections, your com port, and your baud rate and try to re-send.</p> 

Continued on next page

Using PocketMax to Communicate with the V200s, Continued

Using PocketMax to communicate with the V200s, continued

Table 1-3: PocketMax Communication (continued)

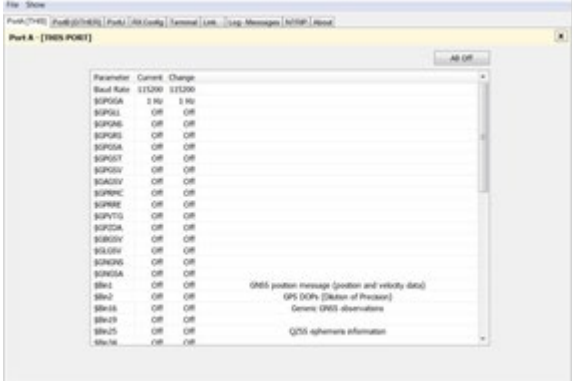
Step	Action
4	<p>The Quick Configuration screen allows you to use “PortA”, “PortB”, and “PortC” tabs to configure the output messages and baud rates of these two ports.</p> <p>The Port displaying “[THIS]” is the port currently connected. “[OTHER]” is the other port. Enable all desired messages for PortA and PortC.</p> <p>Use RxConfig to make basic receiver configurations. To exit the software, click Save Settings and Disconnect. For all other PocketMax questions, please reference the PocketMax User Guide on the HGNS website.</p> 

Firmware Upgrades

Overview

Periodically, Hemisphere GNSS releases firmware upgrades to improve performance, fix bugs, or add new features to a product. To update the firmware on the V200s:

1. Download the latest version of Hemisphere GNSS RightArm from the following link:

[HTTPS://HGNS.COM/RESOURCES-SUPPORT/SOFTWARE.](https://hgns.com/resources-support/software)

RightArm upgrade

Use the following steps to upgrade the RightArm firmware on your V200s:

Table 1-4: RightArm Upgrade

Step	Action
1	<p>Connect the V200s to a computer over serial. Firmware can be loaded over serial port. Set the baud rate of the serial port you are using to 19200.</p> <p>Launch RightArm.</p> <p>Click the Connect button or navigate to Receiver -> Connect.</p> 

Continued on next page

Firmware Upgrades, Continued

RightArm
upgrade,
continued

Table 1-4: RightArm Upgrade (continued)

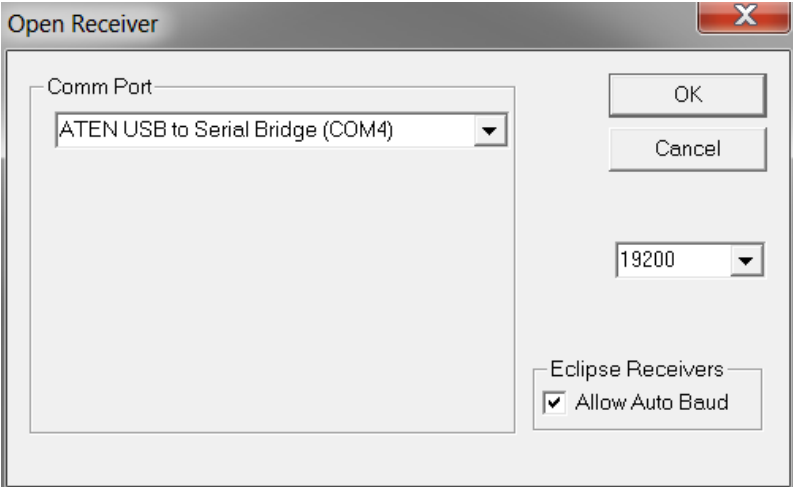
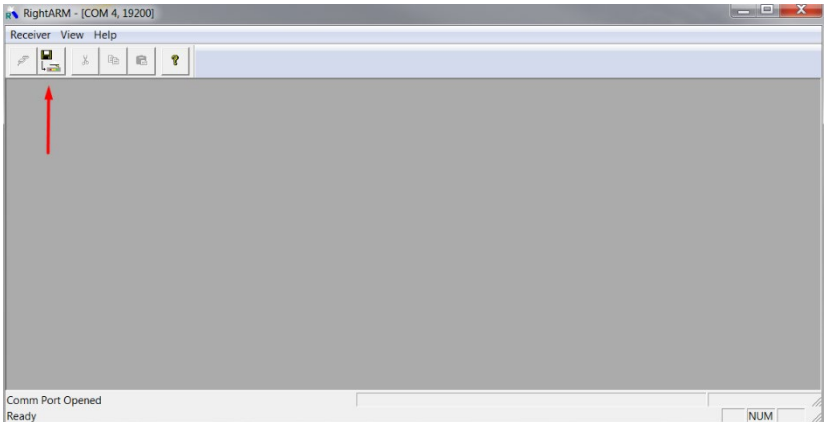
Step	Action
2	<p>Choose the COM port connected to the V200s and click OK.</p>  <p>Note: The baud rate of the serial port should be set to 19200 bps. Select “Allow Auto Baud” to change the baud rate during the firmware upgrade for a faster update.</p>
5	<p>Click the Programming button.</p> 

Continued on next page

Firmware Upgrades, Continued

RightArm
upgrade,
continued

Table 1-4: RightArm Upgrade (continued)

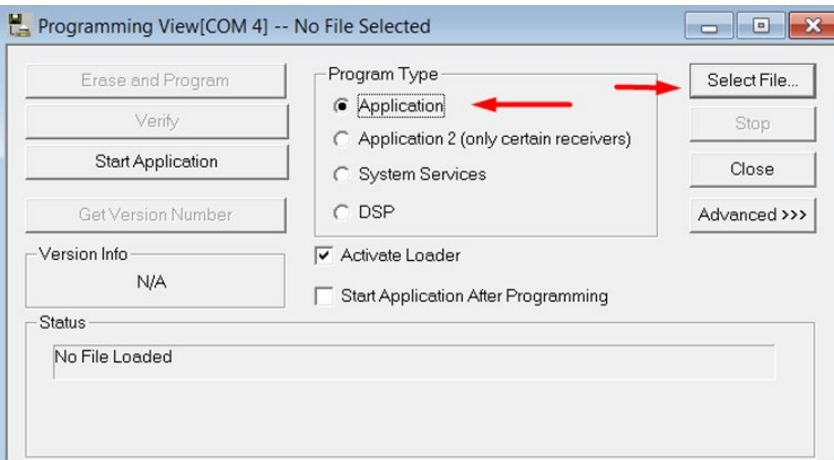
Step	Action
6	<p>Select a Program Type.</p> <p>The V200s has two firmware applications, allowing two different versions of GNSS firmware. Hemisphere GNSS suggests loading the new firmware onto both applications.</p> <p>After the firmware update is completed, check the current GNSS firmware.</p> <p>If the current firmware is not the same as the newly loaded firmware, the V200s could be using the other application. You can switch applications by sending the following command:</p> <p>\$JAPP,OTHER</p>
7	<p>Choose the Application, and press Select File to select the firmware file.</p> 

Continued on next page

Firmware Upgrades, Continued

RightArm
upgrade,
continued

Table 1-4: RightArm Upgrade (continued)

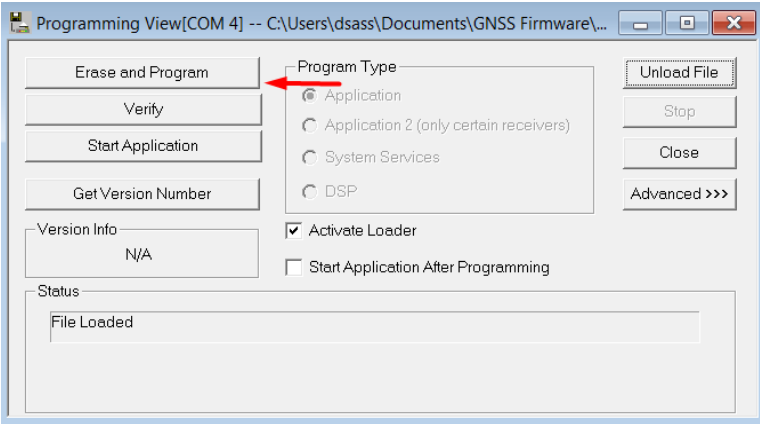
Step	Action
8	<p>Choose the firmware, and click Erase and Program.</p> <p>The Activate Loader checkbox in the Programming View window is selected. After pressing the Erase and Program button, this checkbox will de-select, and the Status field indicates the receiver is in loader mode (ready to receive the new firmware file).</p> 

Continued on next page

Firmware Upgrades, Continued

RightArm
upgrade,
continued

Table 1-4: RightArm Upgrade (continued)

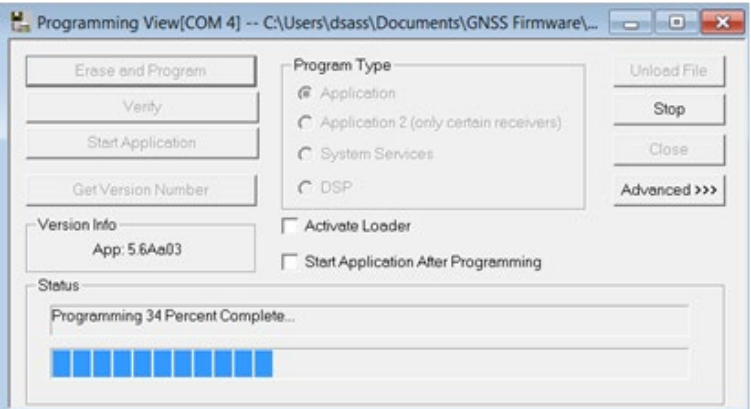
Step	Action
9	<p>Note: If the Activate Loader check box remains selected, power the receiver off and on. When the receiver powers back on, the Activate Loader box should be de-selected.</p> <p>WARNING: Do not to interrupt the power supply to the receiver, and do not interrupt the communication link between the PC and the receiver until programming is complete. Failure to do so may cause the receiver to become inoperable and will require factory repair.</p>  <p>The screenshot shows the 'Programming View[COM 4]' window. It includes buttons for 'Erase and Program', 'Verify', 'Start Application', and 'Get Version Number'. The 'Version Info' section shows 'App: 5.6Aa03'. The 'Program Type' section has radio buttons for 'Application' (selected), 'Application 2 (only certain receivers)', 'System Services', and 'DSP'. There are checkboxes for 'Activate Loader' and 'Start Application After Programming'. A progress bar at the bottom indicates 'Programming 34 Percent Complete...'.</p>
10	<p>After completing the firmware update, Hemisphere GNSS suggests repeating this process for the other application.</p>

Chapter 2: Mounting the V200s

Overview

Introduction This chapter provides instructions on how to mount your V200s GNSS Compass.

Contents

	Topic	See Page
	Mounting the V200s	24
	Surface-mounting the V200s	36
	Pole-mounting the V200s	41

Mounting the V200s

Introduction This section provides information on mounting the V200s in the optimal location, orientation considerations, environmental considerations, and other mounting options.

GNSS satellite reception When deciding where to mount the V200s, consider the following satellite reception recommendations:

- Ensure there is a clear view of the sky available to the V200s so the GNSS and L-band satellites are not masked by obstructions that may reduce system performance.
- Position is based off the primary GNSS antenna located on the end opposite the recessed arrow on the underside of the enclosure.
- Locate any transmitting antennas away from the V200s by at least a few meters to ensure tracking performance is not compromised.
- Ensure cable length is adequate to route into the vessel to reach a breakout box or terminal strip.
- Do not locate the antenna where environmental conditions exceed those specified in [Appendix B, Technical Specifications](#) of this document.

Continued on next page

Mounting the V200s, Continued

VHF interference

VHF interference from such devices as cellular phones and radio transmitters may interfere with GPS operation, however the Vector compass can still track other constellations, maintaining heading and position.

For example, if installing the V200s near marine radios, consider the following:

- VHF marine radio working frequencies (Channels 1 to 28 and 84 to 88) range from 156.05 to 157.40 MHz. The L1 GPS working center frequency is 1575.42 MHz. The bandwidth is +/- 2MHz to +/- 10 MHz, which is dependent on the GNSS antenna and receiver design.
- VHF marine radios emit strong harmonics. The 10th harmonic of VHF radio, in some channels, falls into the GPS working frequency band, which may cause the SNR of GNSS to degrade significantly.
- The radiated harmonic signal strength of different brands/models varies.
- Follow VHF radio manufacturers' recommendations on how to mount their radios and what devices to keep a safe distance away.
- Handheld 5W VHF radios may not provide suitable filtering and may interfere with the V200s's operation if too close.

Before installing the Vector Compass, use the following diagram to ensure there are no nearby devices that may cause VHF interference.

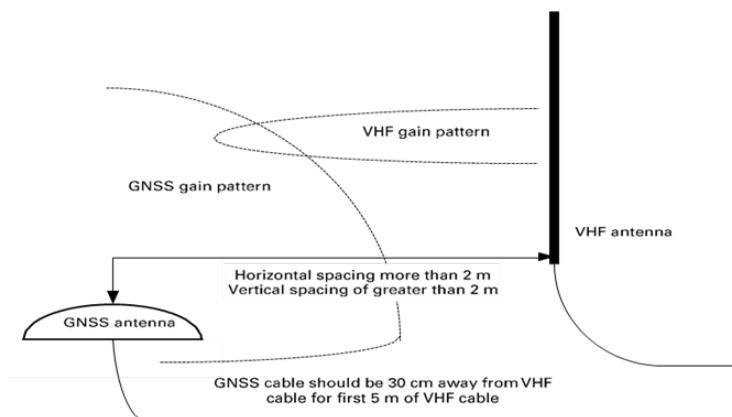

Figure 2-1: V200s distance from nearby VHF radios

Continued on next page

Mounting the V200s, Continued

Environmental considerations

Hemisphere Vector Compasses are designed to withstand harsh environmental conditions. Adhere to the following limits when storing and using the V200s:

- Operating temperature: -30°C to +70°C (-22°F to +158°F)
 - Storage temperature: -40°C to +85°C (-40°F to +185°F)
 - Humidity: 95% non-condensing
-

Mounting orientation

The V200s outputs heading, pitch, and roll readings regardless of the orientation of the antennas. The relation of the antennas to the vessel's axis determines if you need to enter a heading, pitch, or roll bias. The primary antenna is used for positioning and the primary and secondary antennas, working in conjunction, output heading, pitch, and roll values.

The top of the V200s enclosure incorporates a sight design feature to help you align the enclosure on your vessel. Alignment accuracy is approximately +/- 2°.

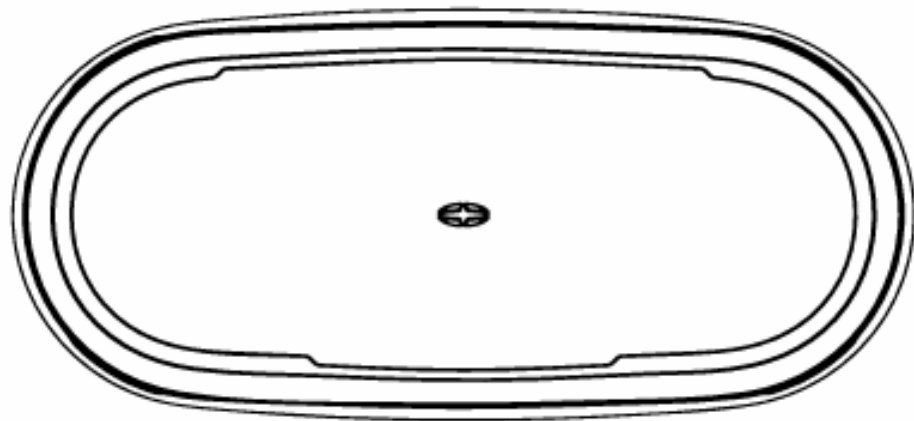

Figure 2-2: Shorter design element

Note: Regardless of which mounting orientation you use, the V200s provides the ability to output the heave of the vessel. This output is available via the **\$GPHEV** message. For more information on this message refer to the [Hemisphere GNSS Technical Reference Manual](#).

Continued on next page

Mounting the V200s, Continued

Parallel orientation

Parallel installation orients the V200s parallel to, and along the centerline of, the axis of the vessel. **This provides a true heading.** In this orientation:

- If you use a gyrocompass and there is a need to align the Vector Compass, you can enter a heading bias in the V200s to calibrate the physical heading to the true heading of the vessel.
 - You may need to adjust the pitch/roll output to calibrate the measurement if the Vector is not installed in a horizontal plane.
-

Perpendicular orientation

You can also install the antennas, so they are oriented perpendicular to the centerline of the vessel's axis. In this orientation:

- Enter a heading bias of +90° if the primary antenna is on the starboard side of the vessel and -90° if the primary antenna is on the port side of the vessel.
 - Configure the receiver to specify the GNSS Compass is measuring the roll axis using **\$JATT,ROLL,YES**.
 - Enter a roll bias to properly output the pitch and roll values.
 - You may need to adjust the pitch/roll output to calibrate the measurement if the Vector is not installed in a horizontal plane.
-

Continued on next page

Mounting the V200s, Continued

Mounting orientation example

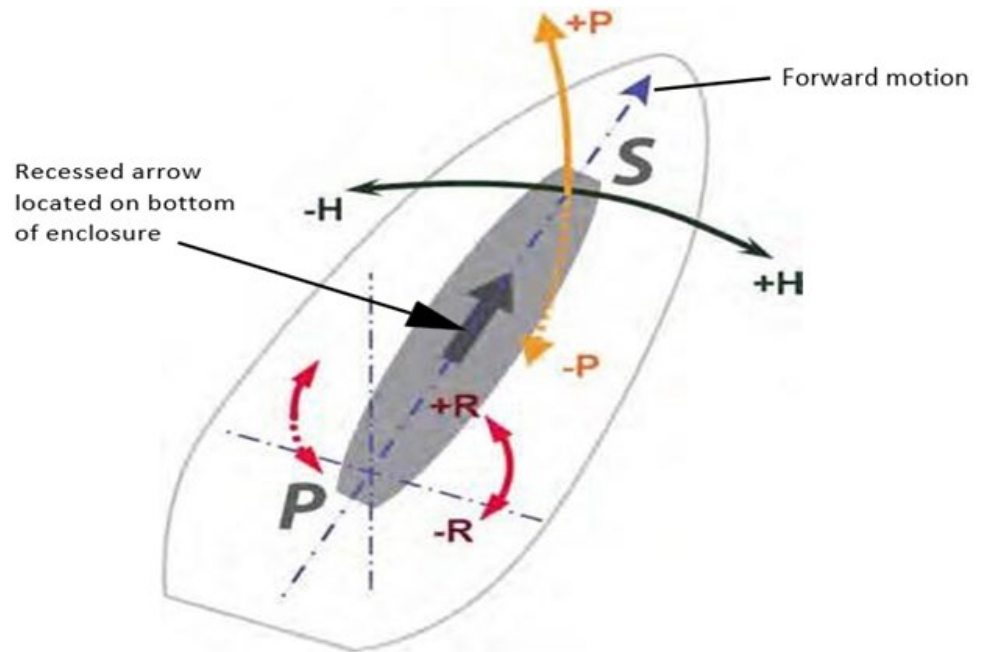

Figure 2-3: Recommended orientation and resulting signs of HPR values

Continued on next page

Mounting the V200s, Continued

Mounting orientation example, continued

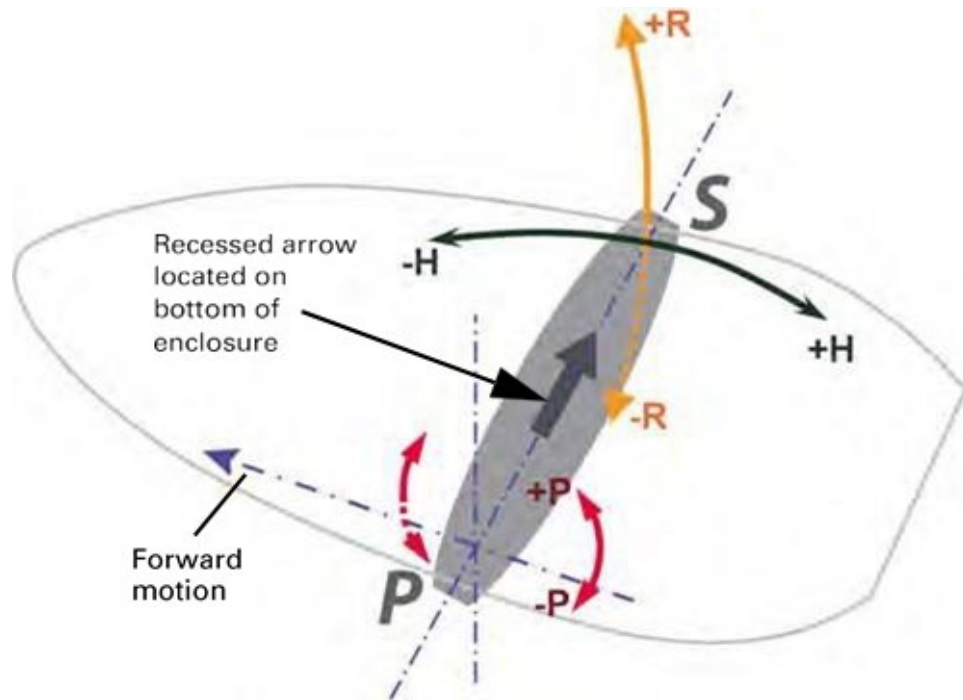

Figure 2-4: Alternate orientation and resulting signs of HPR values

Continued on next page

Mounting the V200s, Continued

V200s dimensions

Figure 2-5 illustrates the physical dimensions of the V200s GNSS Compass.

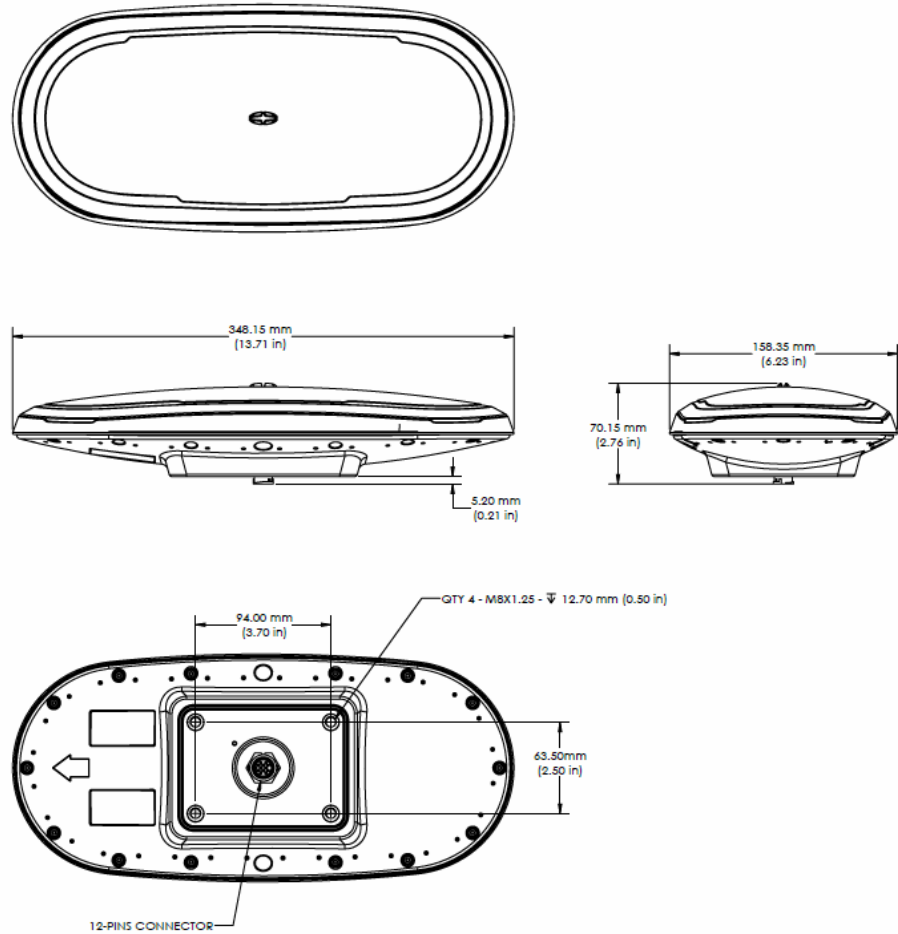

Figure 2-5: V200s dimensions

Continued on next page

Mounting the V200s, Continued

V200s mounting with pole mount accessory

Figure 2-6 illustrates the physical dimensions of the V200s GNSS Compass when mounted using the pole mount accessory.

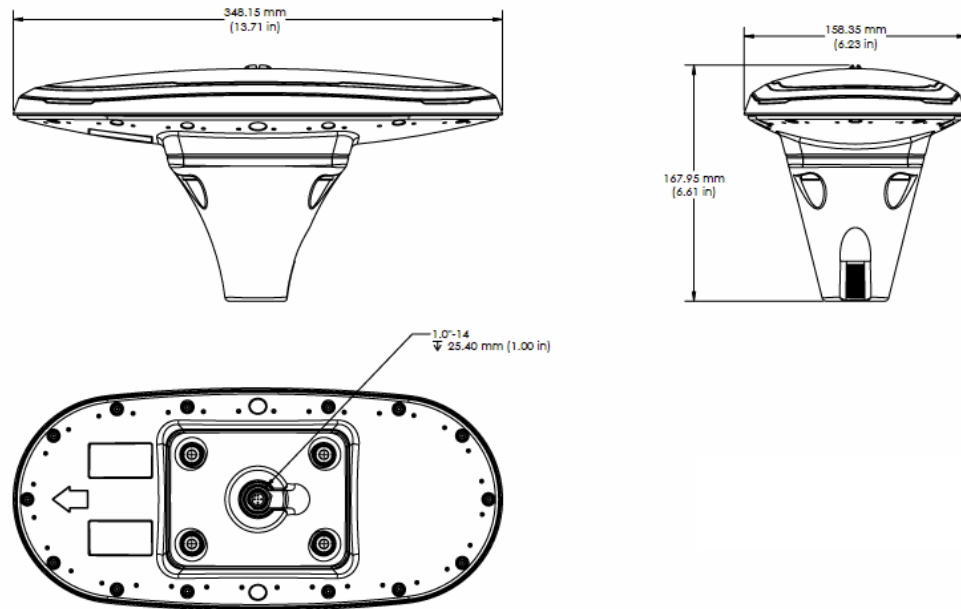

Figure 2-6: V200s with pole mount accessory

Continued on next page

Mounting the V200s, Continued

V200s mounting with low-profile surface mount accessory

Figure 2-7 illustrates the physical dimensions of the V200s GNSS Compass when mounted using the low-profile mount accessory.

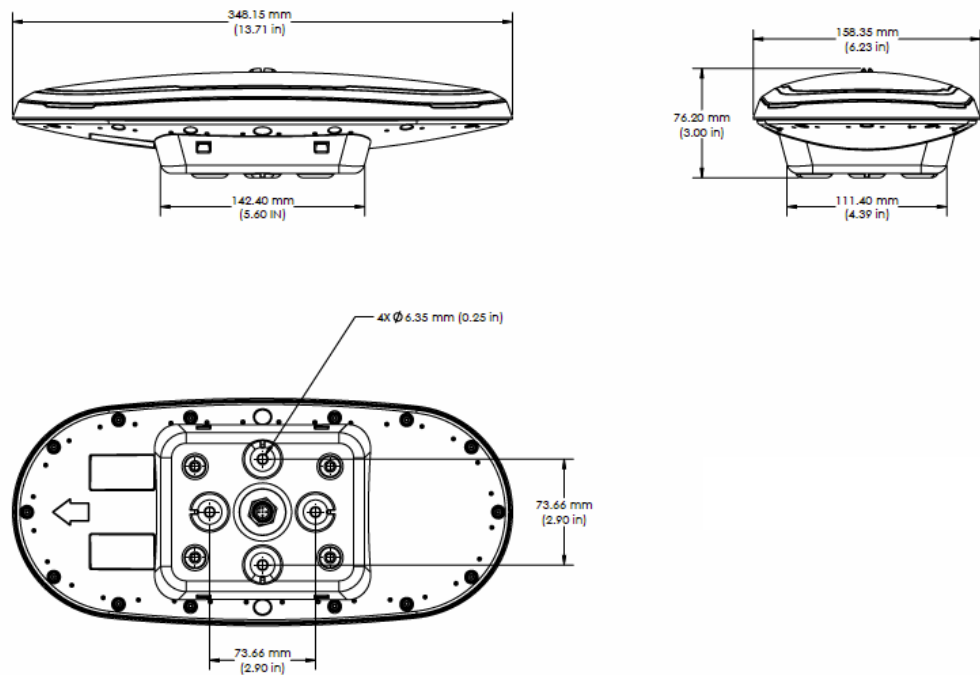

Figure 2-7: V200s with low-profile surface mount accessory

Continued on next page

Mounting the V200s, Continued

V200s mounting with high-profile surface mount accessory

Figure 2-8 illustrates the physical dimensions of the V200s GNSS Compass when mounted using the high-profile mount accessory.

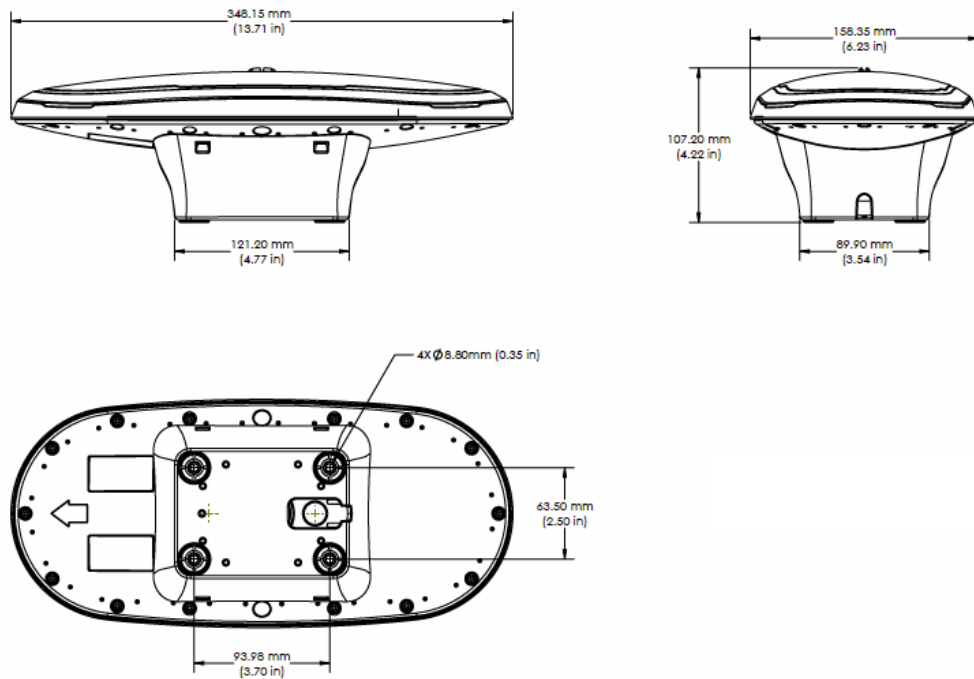

Figure 2-8: V200s with high-profile mount accessory

Continued on next page

Mounting the V200s, Continued

V200s dimensions, continued

If you have another accurate source of heading data on your vessel, such as a gyrocompass, you may use its data to correct for a bias in V200s alignment within the V200s software configuration.

Alternatively, you can physically adjust the heading of the V200s so that it renders the correct heading measurement or add a software offset.

Power/data cable considerations

Before mounting the V200s, consider the following regarding power/data cable routing:

Do	Do not
Ensure cable reaches appropriate power source.	Run cables in areas of excessive heat.
Keep cable away from corrosive chemicals.	Run cables through a door or window jams.
Connect to a data storage device, computer, or other device that accepts GNSS data.	Crimp or excessively bend the cable.
Keep cable away from rotating machinery.	Place tension on the cable.
Remove unwanted slack from the cable at the V200s end.	
Secure along the cable route using plastic wrapping.	

⚠ WARNING:
Improperly installed cable near machinery can be dangerous.

Continued on next page

Mounting the V200s, Continued

Power/data cable considerations, continued

The following table lists the steps to connect the power/data cable to your V200s.

Table 2-1: Connect Power/Data Cable

Step	Action
1	Align the cable connector keyway with the V200s connector key.
2	Rotate the cable ring clockwise until it locks. The locking action is firm; you will feel a positive “click” when it has locked.

⚠ WARNING: When installing the V200n, hand-tighten only. Damage resulting from over-tightening is not covered by the warranty.

Mounting options

The V200s offers four different mounting options:

- Bottom-up Surface Mounting for straight cable
- Top-down Surface Mounting for straight cable
- Top-down Surface Mounting for right-angle cable
- Pole Mounting

Note: Hemisphere GNSS does not supply mounting surface hardware or a mounting pole. You must supply the appropriate mounting hardware required to complete V200s installation.

Surface-mounting the V200s

Surface-mounting the V200s

Be mindful of the following when planning your installation:

- If you need the GNSS-assisted roll measurement, install the V200s perpendicular to the vessel’s axis. If you do not need this measurement, install the V200s parallel with the vessel’s axis.
 - Hemisphere GNSS does not supply mounting surface hardware or a mounting pole. You must supply the appropriate hardware or mounting pole required to complete V200s installation.
 - You can enter a software offset to accommodate for a heading measurement bias due to installation.
 - The flat surface may be fabricated per your installation, an off-the-shelf item (such as a radar mounting plate), or an existing surface on your vessel.
-

Surface-mounting the V200s from the bottom up for straight cable

Complete the following steps to Surface-mount the V200s from the bottom up.

Table 2-2: Bottom-up, Surface-mounting the V200s

Step	Action
1	Determine the desired location and proper orientation for the V200s. See “ Mounting Orientation ” for information on determining the desired orientation.
2	Go to the HGNSS website/Technical Documentation/V200 Mounting Template .
3	Use the supplied V200 Mounting Template drawing or photocopy the bottom of the V200s to plan the mounting hole locations. If using a photocopy, make sure it is scaled one-to-one with the mounting holes on the bottom of the V200s.
4	If required, use a center punch to mark the hole centers on the mounting surface, then drill the mounting holes with a 9mm (.35 in) bit appropriate for the surface.

Continued on next page

Surface-mounting the V200s, Continued

Surface-mounting the V200s, continued

Table 2-2: Bottom-up, Surface-mounting the V200s (continued)

Step	Action	
5	Place the V200s over the mounting holes and insert the mounting screws through the bottom of the mounting surface into the V200s.	
6	Tighten to a torque of 8 - 10 lbs.-ft. The maximum thread depth engagement must be no more than 0.50 in!	
	<table border="1"> <tr> <td data-bbox="581 646 797 724">⚠ WARNING:</td> <td data-bbox="797 646 1398 724">Damage resulting from over-tightening is not covered by the warranty.</td> </tr> </table>	⚠ WARNING:
⚠ WARNING:	Damage resulting from over-tightening is not covered by the warranty.	

Continued on next page

Surface-mounting the V200s, Continued

Surface-mounting the V200s from the top down for straight cable and for right-angle cable

Complete the following steps to surface-mount the V200s from the top down.

Table 2-3: Top down, Surface-mounting the V200s





Step	Action
1	<p>Secure the Surface Mount Adapter (676-0043-10) to the V200s using the supplied mounting hardware. Tighten to a torque of 8 - 10 lbs.-ft. The maximum thread depth engagement must be no more than 0.50 in!</p> <div data-bbox="716 800 1265 1081" data-label="Image"> <p>A white, rectangular plastic Surface Mount Adapter with a central circular cutout and several smaller circular holes around the perimeter. It has raised edges and a textured surface.</p> </div> <p data-bbox="761 1125 1219 1192">Figure 2-9: Surface Mount Adapter (676-0043-10)</p> <div data-bbox="716 1236 1265 1444" data-label="Image"> <p>The Surface Mount Adapter is shown mounted onto a white, oval-shaped V200s device. The adapter is secured with four screws, one in each corner. The V200s device has a central circular cutout and several smaller holes around the perimeter.</p> </div> <p data-bbox="638 1486 1346 1520">Figure 2-10: Surface Mount Adapter secured to V200s</p>
2	<p>Determine the desired location and proper orientation for the V200s. See Mounting Orientation for information on determining the desired orientation.</p>

Continued on next page

Surface-mounting the V200s, Continued

Surface-mounting the V200s from the top down for straight cable and for right-angle cable, continued

Table 2-3: Top down, Surface-mounting the V200s (continued)







Step	Action	
3	Select the applicable surface mount:	
	Select this surface mount if you will thread the cable straight down.	Select this surface mount if you will thread the cable towards the back of the unit.
		
	<p align="center">Figure 2-11: V200 Low-Profile Surface Mount (676-0041-10)</p>	<p align="center">Figure 2-12: V200 Right-Angle Surface Mount (676-0042-10)</p>
4	Place the surface mount in the desired location on the installation surface.	
5	If required, use a center punch to mark the hole centers, then drill the mounting holes with bit appropriate for the surface.	
	<p>Note: The diameter of the 676-0041-10 mounting holes is 6.4 mm (.25 in)</p>	<p>Note: The diameter of the 676-0042-10 mounting holes is 9 mm (.35 in)</p>
		
	<p align="center">Figure 2-13: 676-0041-10 Mounting Holes</p>	<p align="center">Figure 2-14: 676-0042-10 Mounting Holes</p>
6	Secure the mount to the installation surface. Tighten to a maximum torque of 10 lbs.-ft.	

Continued on next page

Surface-mounting the V200s, Continued

Surface-mounting the V200s from the top down for straight cable and for right-angle cable, continued

Table 2-3: Top down, Surface-mounting the V200s (continued)



Step	Action				
7	Thread the cable into through the surface mount, then connect the cable to the unit.				
8	<p>Carefully secure the mount to the V200s by placing it into the surface mount until the four latches snap into place, first on one side, and then the other.</p> <table border="1" data-bbox="581 716 1393 932"> <thead> <tr> <th data-bbox="581 716 992 751">Straight</th> <th data-bbox="992 716 1393 751">Right-Angle</th> </tr> </thead> <tbody> <tr> <td data-bbox="581 751 992 932">  </td> <td data-bbox="992 751 1393 932">  </td> </tr> </tbody> </table> <p>Figure 2-15: Adapters with both sides secured</p>	Straight	Right-Angle		
Straight	Right-Angle				
					
	<p>Note: To remove the V200s, simply reverse the process by pushing in the clips on one side, at which point the V200s can easily be removed.</p>				

Pole-mounting the V200s

Pole-mounting the V200s

Complete the following steps to pole-mount the V200s:

Table 2-4: Pole-mounting the V200s

Step	Action		
1	Determine the desired location and proper orientation for the V200s. See Mounting Orientation for information on determining the desired orientation.		
2	<p>Thread the jam nut onto the 1-inch pole, then thread the pole mount.</p>  <p>Figure 2-16: Pole mount with jam nut loosely threaded</p> <table border="1" data-bbox="581 1108 1398 1188"> <tr> <td data-bbox="581 1108 808 1188">WARNING:</td> <td data-bbox="808 1108 1398 1188">Do not tighten the pole mount to more than 4 lbs-ft.</td> </tr> </table>	WARNING:	Do not tighten the pole mount to more than 4 lbs-ft.
WARNING:	Do not tighten the pole mount to more than 4 lbs-ft.		
3	Thread the cable either through the hollow pole or through the opening in the pole mount.		
4	<p>Connect the cable to the V200s, then secure the pole mount to the V200s using the supplied mounting hardware. Tighten to a torque of 8 - 10 lbs.-ft. The maximum thread depth engagement must be no more than 0.50 in!</p>  <p>Figure 2-17: Pole mount secured to V200s</p>		

Continued on next page

Pole-mounting the V200s, Continued

Pole-mounting the V200s, continued

Table 2-4: Pole-mounting the V200s (continued)

Step	Action
5	<p>Verify the orientation of the unit, then tighten the jam nut to the bottom of the pole mount to a torque of 8 – 10 lbs.-ft.</p>  <p>Figure 2-18: Pole mount with jam nut tightly threaded to secure V200s orientation</p>

Chapter 3: Connecting the V200s

Overview

Introduction This chapter provides instructions on how to connect your V200s receiver.

Contents

	Topic	See Page
	Ports	44
	Selecting Baud Rates and Message Types	45
	Connecting the V200s to External Devices	46

Ports

Overview The V200s offers RS-232 and RS-422 communication.

Serial ports The V200s supports:

- two independent full-duplex RS-232 (Ports A and B) and one RS-422 Tx (Port C); or
- one full-duplex RS-422 (Port A) and one RS-422 Tx (Port C)

The V200s automatically detects and switches to the appropriate serial protocol on Ports A and B.

Note: The V200s has maximum baud rate of 115200.

Serial port configuration You may configure the GNSS receiver to output any combination of data.

Note: For successful communications, use the 8-N-1 protocol and set the baud rate of the V200s's serial ports to match that of the devices to which they are connected. Flow control is not supported.

Selecting Baud Rates and Message Types

Baud rates & Message types

When selecting your baud rate and message types, use the following formula to calculate the bits/sec for each message and sum the results to determine the baud rate for your required data throughput.

Message output rate * Message length (bytes) * bits in byte = Bits/second
(1 character = 1 byte, 8 bits = 1 byte, use 10 bits/byte to account for overhead).

For information on message output rates refer to the [Hemisphere GNSS Technical Reference Manual](#).

Connecting the V200s to External Devices

Recommendations for connecting to other devices

When interfacing with other serial devices, ensure the transmit data output and the signal grounds from the V200s are connected to the data input of the other device. The signal grounds must also be connected.

For a list of Hemisphere GNSS commands, please refer to the [Hemisphere GNSS Technical Reference Manual](#).

Power/data cable considerations

The V200s automatically detects and switches to the correct serial protocol on Ports A and B.

Continued on next page

Connecting the V200s to External Devices, Continued

Power/data cable pin-out specifications

The V200s uses a 12-pin connector and supports RS-232 and RS-422. The V200s can auto-detect and auto-switch between RS-232 and RS-422.

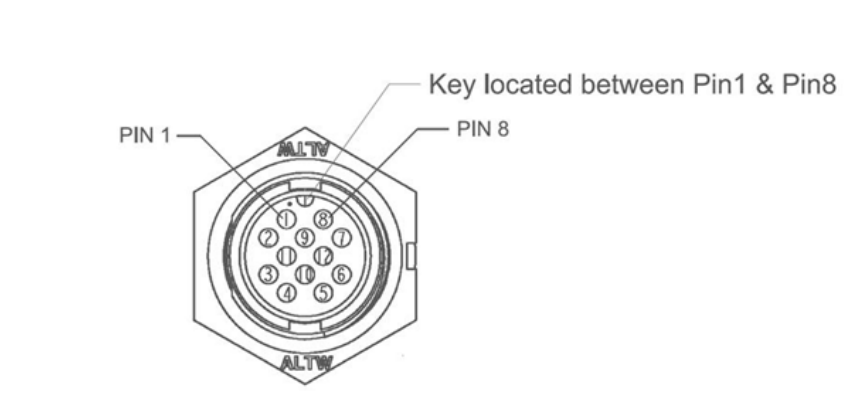

Figure 3-1: V200s pin-out assignments

Table 3-1 shows the cable pin-out specifications.

Table 3-1: V200s Pinouts (Device Out)

Pin	Signal
1	RS232 Tx B/RS422 Tx A+
2	RS232 Rx B/RS422 Rx A-
3	1PPS
4	Alarm
5	Power In
6	RS422 TX C+
7	Digital Ground
8	RS232 Rx A /RS422 Rx A+
9	RS232 Tx A / RS422 Tx A-
10	Power Ground
11	Drain
12	RS422 Tx C-

Chapter 4: Understanding the V200s

Overview

Introduction

The GNSS receiver begins tracking satellites when it powers up and is placed outside in an open area. Position and heading accuracy vary depending upon location and environment. Position performance can be improved with RTK or DGNS.

The following sections provide the steps to configure your V200s to use Atlas, SBAS, or RTK.

Note: Differential source and RTK status impact only positioning and heave. There is no impact to heading, pitch, or roll.

Contents

	Topic	See Page
	GNSS Overview	49
	Differential Operation	50
	SBAS Tracking	51
	Atlas L-band	52
	Supplemental Sensors	53
	Time Constants	56

GNSS Overview

GNSS operation The GNSS receiver is always operating, regardless of the DGNSS mode of operation. The following sections describe the general operation of the V200s's internal GNSS receiver.

Note: Differential source and status have no impact on heading, pitch, or roll. They only have an impact on positioning and heave.

The V200s provides accurate and reliable heading and position information at high update rates. To accomplish this task, the V200s uses a high performance GNSS receiver and two antennas for GNSS signal processing.

One antenna is designated as the primary GNSS antenna and the other is the secondary GNSS antenna. Positions computed by the V200s are referenced to the phase center of the primary GNSS antenna. Heading data references the Vector formed from the primary GNSS antenna phase center to the secondary GNSS antenna phase center.

The heading arrow located on the bottom of the V200s enclosure defines system orientation. The arrow points in the direction the heading measurement is computed (when the antenna is installed parallel to the fore-aft line of the vessel). The secondary antenna is directly above the arrow.

Differential Operation

Differential (DGNSS) operation

The V200s delivers positioning accuracies of 2.5 m 95% and provides positioning quality to better than 0.6 m 95% using differential corrections received through the internal SBAS demodulator or through Atlas L-band.

SBAS Tracking

SBAS tracking The V200s features two-channel tracking that provides an enhanced ability to maintain a lock on an SBAS satellite when more than one satellite is in view. This redundant tracking approach results in more consistent tracking of an SBAS signal in areas where signal blockage of a satellite is possible.

Atlas L-band

Atlas L-band

Atlas L-band corrections are available worldwide. With Atlas, the positioning accuracy does not degrade as a function of distance to a base station, as the data content is not composed of a single base station's information, but an entire network's information.

The V200s can calculate a position with 30 cm RMS (horizontal) accuracy.

To configure the receiver to use Atlas L-band, a subscription must be purchased.

Supplemental Sensors

Overview

The V200s has an integrated supplemental sensor that is enabled by default. You can enable/disable the sensor.

The sensor acts to reduce the RTK search volume, which improves heading startup and reacquisition times. This improves the reliability and accuracy of selecting the correct heading solution by eliminating other possible erroneous solutions.

The [Hemisphere GNSS Technical Reference Manual](#) describes the commands and methodology required to recalibrate, query, or change the sensor status.

Tilt aiding

The V200s' s internal sensor is factory calibrated and enabled by default and constrains the RTK heading solution beyond the volume associated with a fixed antenna separation.

The V200s knows the approximate inclination of the secondary antenna with respect to the primary antenna. The search space defined by the sensor is reduced to a horizontal ring on the sphere's surface by reducing the search volume and decreases startup and reacquisition times (Figure 4-1).

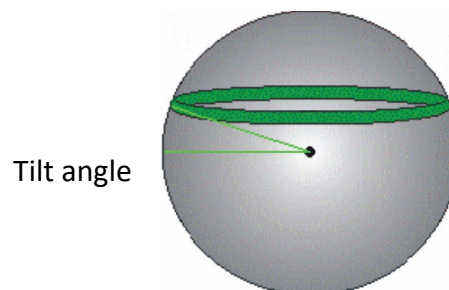

Figure 4-1: V200s tilt aiding

Continued on next page

Supplemental Sensors, Continued

Gyro aiding

The V200s's internal sensor reduces reacquisition times when a GNSS heading is lost due to blocked satellite signals. The sensor provides a relative change in angle since the last computed heading and defines the search space as a wedge-shaped location (see Figure 4-2).

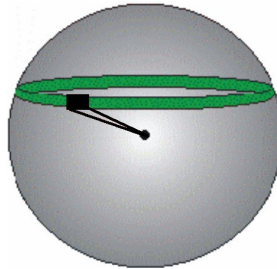

Figure 4-2: V200s gyro aiding

The gyro aiding accurately smooths the heading output and the ROT. The sensor also provides an alternate source of heading, accurate to within 1° per minute for up to three minutes in times of GNSS loss for either antenna. If the outage lasts longer than three minutes, the sensor will have drifted too far and the V200s begins outputting null fields in the heading output messages. There is no user control over the timeout period of the sensor.

The sensor initializes itself at power up and during initialization, or you can calibrate it as outlined in the [Hemisphere GNSS Technical Reference Manual](#).

Continued on next page

Supplemental Sensors, Continued

Gyro aiding, continued

For optimal performance, when the sensor is first initializing, the dynamics the sensor experiences during this warm-up period are similar to the regular operating dynamics.

Gyro-aiding updates the post HTAU-smoothed heading. As a result, if the HTAU value is increased while gyro aiding is enabled, there will be little to no lag in heading output due to vessel maneuvers.

The [Hemisphere GNSS Technical Reference Manual](#) includes information on setting an appropriate HTAU value for the application.

Time Constants

Overview

The V200s incorporates user-configurable time constants that can provide a degree of smoothing to the heading, pitch, Rate-of-Turn (ROT), Course-over-Ground (COG), and speed measurements.

You can adjust these parameters depending on the expected dynamics of the vessel. For example, increasing the time is reasonable if the vessel is very large and is not able to turn quickly or would not pitch quickly. The resulting values would have reduced “noise,” resulting in consistent values with time.

If the vessel is quick and nimble, increasing this value can create a lag in measurements.

If you are unsure on how to set this value, it is best to be conservative and leave it at the default setting.

Note: For heading and rate of turn there is no lag once the sensor is calibrated and enabled.

Formulas for determining the level of smoothing are located in the [Hemisphere GNSS Technical Reference Manual](#). If you are unsure how to set this value, it is best to be conservative and leave the default setting.

Heading

Use the **\$JATT,HTAU** command to adjust the level of responsiveness of the true heading measurement provided in the **\$GPHDT** message. The default value of this constant is 0.2 seconds of smoothing when gyro-aid is enabled.

By disabling gyro-aid, the equivalent default value of the heading time constant should be 0.5 seconds of smoothing. This is not automatic, and therefore it must be manually entered.

Note: Increasing the time constant increases the level of heading smoothing and increases lag (with gyro-aid disabled).

Continued on next page

Time Constants, Continued

Pitch

Use the **\$JATT,PTAU** command to adjust the level of responsiveness of the pitch measurement provided in the **\$PSAT,HPR** message. The default value of this constant is 0.5 seconds of smoothing.

Note: Increasing the time constant increases the level of pitch smoothing and increases lag.

Rate-of-Turn (ROT)

Use the **\$JATT,HRTAU** command to adjust the level of responsiveness of the ROT measurement provided in the **\$GPROT** message. The default value of this constant is 2.0 seconds of smoothing.

Note: Increasing the time constant increases the level of ROT smoothing.

Course-Over-Ground (COG)

Use the **\$JATT,COGTAU** command to adjust the level of responsiveness of the COG measurement provided in the **\$GPVTG** message. The default value of this constant is 0.0 seconds of smoothing.

Note: Increasing the time constant increases the level of COG smoothing.

COG is computed using only the primary GNSS antenna and its accuracy depends upon the speed of the vessel (noise is proportional to 1/speed).

This value is invalid when the vessel is stationary, as tiny movements due to calculation inaccuracies are not representative of a vessel's movement.

Speed

Use the **\$JATT,SPDTAU** command to adjust the level of responsiveness of the speed measurement provided in the **\$GPVTG** message. The default value of this parameter is 0.0 seconds of smoothing.

Note: Increasing the time constant increases the level of speed measurement smoothing.

Chapter 5: Operating the V200s

Overview

Introduction This chapter provides information on how to power and operate your V200s receiver.

Contents

	Topic	See Page
	Powering the V200s	59

Powering the V200s

Power connections

For best performance, use a clean and continuous power supply. See Table B-3 for complete power specifications.

If using an unterminated cable, before powering up the V200s, you must terminate the wires of the power cable as required. There are a variety of power connectors and terminals on the market from which to choose, depending on your specific requirements. Refer to Figure 2-9 and Table 2-4 for pinout specifications.

⚠ WARNING:

Do not apply a voltage higher than 36 VDC. The V200s is protected from a reversed power connection. A 3-Amp power fuse is recommended for the protection of personnel and the system.

The V200s starts when sufficient voltage is applied to the power leads of the extension cable.

Electrical isolation

The V200s's power supply is isolated from the communication lines and the PC-ABS plastic enclosure isolates the electronics mechanically from the vessel (addressing the issue of vessel hull electrolysis).

Appendix A: Troubleshooting

Overview

Introduction

Appendix A provides troubleshooting for common problems.

Contents

	Topic	See Page
	Troubleshooting	61

Troubleshooting

Appendix A troubleshooting

Symptom	Possible Solution
Receiver fails to power	<ul style="list-style-type: none"> • Verify polarity of power leads. • Check integrity of power cable connectors. • Check power input voltage (9 to 36 VDC). • Check the voltage coming out of the connector at the end of the cable. • Check current restrictions imposed by power source (minimum available should be > 1.0 A).
No data from V200s	<ul style="list-style-type: none"> • Check receiver power status to ensure the receiver is powered. • Verify desired messages are activated (using PocketMax or \$JSHOW command in any terminal program). • Ensure the baud rate of the V200s matches that of the receiving device. • Check integrity and connectivity of power and data cable connections.
Random data from V200s	<ul style="list-style-type: none"> • Verify the RTCM or binary messages are not output accidentally (send a \$JSHOW command) • Ensure the baud rate of the V200s matches that of the remote device. • The volume of data requested for output by the V200s could be higher than the current baud rate supports.
No GNSS lock	<ul style="list-style-type: none"> • Verify the V200s has a clear view of the sky. • Use PocketMax to check how many satellites are in view and the SNR values.

Continued on next page

Troubleshooting, Continued

Appendix A troubleshooting , continued

Symptom	Possible Solution
No SBAS lock	<ul style="list-style-type: none"> • Verify the V200s has a clear view of the sky. • Set SBAS mode to automatic with the \$JWAASPRN,AUTO command. <div style="border: 1px solid black; padding: 5px; margin-top: 10px;"> <p>Note: SBAS lock is only possible if you are in an appropriate SBAS region; currently, there is limited SBAS availability in the southern hemisphere.</p> </div>
No Atlas	<ul style="list-style-type: none"> • First, check to see for an Atlas Basic subscription by sending \$JK,SHOW to see which commands are listed. Or, connect to PocketMax, go to the About tab, and check the listed activations. • Ensure you are tracking the correct Atlas satellite, or set the receiver to 'Auto-Tune' by sending \$JFREQ,AUTO

Continued on next page

Troubleshooting, Continued

Appendix A troubleshooting , continued

Symptom	Possible Solution
No heading or incorrect heading value	<ul style="list-style-type: none"> • Check CSEP value is constant without varying more than 1 cm (0.39 in)—larger variations may indicate a high multipath environment and require moving the receiver location. • Heading is from primary GNSS antenna to secondary GNSS antenna, so the arrow on the underside of the V200s is directed to the bow side. • \$JATT,SEARCH command forces the V200s to acquire a new heading solution (unless gyro is enabled). • Enable GYROAID to provide heading for up to three minutes during GNSS signal loss. • Enable TILTAID to reduce heading search times. • Monitor the number of satellites and SNR values for both antennas within PocketMax—at least four satellites should have strong SNR values. • The volume of data requested for output by the V200s could be higher than the current baud rate supports.
No DGPS position in external RTCM mode	<ul style="list-style-type: none"> • Verify the baud rate of the RTCM input port matches the baud rate of the external source. • Verify the pinout between the RTCM source and the RTCM input port (transmit from the source must go to receive of the RTCM input port and grounds must be connected).

Appendix B: Technical Specifications

Introduction Appendix B provides the V200s technical specifications, and the V200s certification information.

Contents

Topic	See Page
V200s Technical Specifications	65

V200s Technical Specifications

V200s technical specifications

Table B-1: V200s sensor and positioning accuracy

Item	Specification
Receiver type	Vector sFreq GNSS Compass
Signals Received	GPS, GLONASS, BeiDou, Galileo, QZSS ¹ , and Atlas
Channels	424
GPS sensitivity	-142 dBm
SBAS tracking	2-channel, parallel tracking
Update rate (position and heading)	10 Hz standard, 20 Hz optional
Positioning accuracy (Standard)	2.0 m RMS (Autonomous, no SA) 0.50 m RMS (SBAS)
Positioning accuracy (Optional)	1.2 m RMS (Autonomous, no SA) ¹ 0.30 m RMS (SBAS) ² 0.50 m RMS (Atlas) ³
Heading accuracy (GNSS)	1.5° RMS ¹ 0.75° RMS optional ¹
Heave accuracy (GNSS)	30 cm ⁴
Pitch/Roll accuracy	1.5° RMS
Rate of turn	90°/s maximum
Cold start	60 s typical (no almanac or RTC)
Warm start	20 s typical (almanac and RTC)
Hot start	1 s typical (almanac, RTC, and position)
Heading fix	10 s typical (valid position)
Maximum speed	1,850 kph (999 kts)
Maximum altitude	18,288m (60,000 ft)
Compass safe distance	50 cm ⁵
Differential options	Atlas, SBAS

Continued on next page

V200s Technical Specifications, Continued

V200s technical specifications, continued

Table B-2: Communication

Item	Specification
Connector ports	12-pin
Ports	RS-232 or RS-422
Baud Rates	4800-115200
Correction I/O Protocol	RTCM SC-104
Data I/O Protocol	NMEA 0183, Hemisphere proprietary

Table B-3: Power

Item	Specification
Input voltage	6 to 36 VDC
Power consumption	(multi-GNSS, typical continuous draw @ 12V)
SBAS:	3.2 W
Atlas:	3.6 W
Current consumption	TBD
Power isolation	Isolated to enclosure
Reverse polarity protection	Yes

Continued on next page

V200s Technical Specifications, Continued

V200s technical specifications, continued

Table B-4: Mechanical

Item	Specification
Dimensions	
No Mount:	34.8 L x 15.8 W x 6.5 H (cm)
LP Flat Mount:	34.8 L x 15.8 W x 7.6 H (cm)
HP Flat Mount:	34.8 L x 15.8 W x 10.7 H (cm)
Pole Mount:	34.8 L x 15.8 W x 16.8 H (cm)
Notes:	Tolerances for the above measurements are -0/+0.25 cm. Please refer to drawings in the Mounting the V200s section of this document for details.
Weight (no mount)	0.75 kg
Power/data connector	12-pin
Aiding Devices	Provides smooth heading, fast heading reacquisition and reliable 1° per minute heading for periods up to 3 minutes when loss of GPS has occurred ²
Gyro:	
Tilt Sensor:	Provides pitch and roll data and assist in fast start-up and reacquisition of heading solution.

Table B-5: Environmental

Item	Specification
Operating temperature	-40°C to + 70°C (-22°F to + 158°F)
Storage temperature	-40°C to + 85°C (-40°F to + 185°F)
Humidity	95% non-condensing
Enclosure	ISO 60529:2013 for IPx6/IPx7/IPx9
Vibration	IEC 60945:2002 Section 8.7 Vibration
EMC	IEC60945:2002 EN 301 489-1 V2.1.1 EN 301 489-5 V2.1.1 EN 301 489-19 V2.1.0 EN 303 413 V1.1.1

Continued on next page

V200s Technical Specifications, Continued

V200s technical specifications, continued

Table B-6: Certifications

Certification
RCM (Australia)

- 1 Depends on multipath environment, number of satellites in view, satellite geometry, no SA, and ionospheric activity
 - 2 Depends on multipath environment, number of satellites in view, SBAS coverage and satellite geometry
 - 3 Depends on multipath environment, number of satellites in view, and satellite geometry
 - 4 Based on a 40 second time constant
 - 5 This is the minimum safe distance measured when the product is placed in the vicinity of the steering magnetic compass. The ISO 694 defines “vicinity” relative to the compass as within 5 m (16.4 ft) separation
-

Appendix C: Commands and Messages

Overview

Introduction

Appendix C contains the common commands and messages used by the V200s. Reference the following tables for sending and receiving commands and messages.

For information on message output rates refer to the [Hemisphere GNSS Technical Reference Manual](#).

Example message	Rate	Bytes	Bits in byte	Bits/sec
GPHDT	10	20	10	2000
GPROT	5	18	10	900
GPHDG	1	33	10	330
GPGGA	1	83	10	830
GPZDA	1	38	10	380
			Total	4440

Contents

	Topic	See Page
	Serial Commands	70
	NMEA 0183 Messages	73
	Binary Messages	77
	Index	80

Serial Commands

Serial commands

The V200s has a maximum baud rate of 115200.

Note: When selecting baud rate and message types, use the following formula and example to calculate the bits/sec for each message and then sum the results to determine the baud rate for your required data throughput.

Message length (bytes) * bits in byte = Bits/second
 (1 character = 1 byte, 8 bits = 1 byte, use 10 bits/byte to account for overhead)

Table C-1: Serial commands

Command	Description
\$JAGE	Specify maximum DGPS (COAST) correction age (6 to 8100 seconds)
\$JAPP	Query or specify receiver application firmware
\$JASC	Specify ASCII messages to output to specific ports
\$JATT, COGTAU	Set/query COG time constant (0.0 to 3600.0 sec)
\$JATT, CSEP	Query antenna separation
\$JATT, EXACT	Enable/disable internal filter reliance on the entered antenna separation
\$JATT, GYROAID	Enable/disable gyro
\$JATT, HBIAS	Set/query heading bias (-180.0° to 180.0°)
\$JATT, HELP	Show the available commands for GNSS heading operation and status
\$JATT, HIGHMP	Set/query the high multipath setting for use in poor GNSS environments
\$JATT, HRTAU	Set/query ROT time constant (0.0 to 3600.0 sec)
\$JATT, HTAU	Set/query heading time constant (0.0 to 3600.0 sec)
\$JATT, LEVEL	Enable/disable level operation
\$JATT, NMEAHE	Change the HDG, HDM, HDT, and ROT message headers between GP and HE
\$JATT, PBIAS	Set/query pitch/roll bias (-15.0° to 15.0°)

Continued on next page

Serial Commands, Continued

Serial
commands,
continued

Table C-1: Serial commands (continued)

Command	Description
\$JATT, PTAU	Set/query pitch time constant (0.0 to 3600.0 sec)
\$JATT, ROLL	Configure for roll or pitch GNSS orientation
\$JATT, SEARCH	Force a new GNSS heading search
\$JATT, SPDTAU	Set/query speed time constant (0.0 to 3600.0 sec)
\$JATT, SUMMARY	Display a summary of the current Vector settings
\$JATT, TILTAID	Enable/disable accelerometer, pre-calibrated
\$JATT, TILTCAL	Calibrate accelerometers
\$JBAUD	Specify RS-232, RS-422 (output) communication rate
\$JBIN	Specify binary messages to output to specific ports
\$JDIFF	Query or specify differential correction mode
\$JGEO	Query or specify SBAS for current location and SBAS satellites
\$JI	Query unit's serial number and firmware versions
\$JOFF	Turn off all data messages
\$JQUERY,GUIDE	Query accuracy suitability for navigation
\$JMODE,GPSONLY,YES	GPS only mode

Continued on next page

Serial Commands, Continued

Serial
commands,
continued

Table C-1: Serial commands (continued)

Command	Description
\$JMODE,GPSONLY,NO	Multi-GNSS mode
\$JRESET	<p>Reset unit's configuration to firmware defaults</p> <div style="border: 1px solid black; padding: 5px;"> <p>Note: \$JRESET clears all parameters. For the V200s you will have to issue the \$JATT, FLIPBRD,YES command to properly redefine the circuitry orientation inside the product once the receiver has reset. Failure to do so will cause radical heading behavior.</p> </div> <p>You can also issue the \$JRESET command with an optional field as follows:</p> <ul style="list-style-type: none"> • \$JRESET,ALL does everything \$JRESET does, plus it clears almanacs • \$JRESET,BOOT does everything \$JRESET,ALL does, plus clears use of the real-time clock at startup, clears use of backed-up ephemeris and almanacs, and reboots the receiver when done
\$JSAVE	Save session's configuration changes

NMEA 0183 Messages

V200s **Table C-2: NMEA 0183 and other messages**
NMEA 0183 and
other messages

In Table C-2 the Info Type value is one of the following:

- P = Position
- V = Velocity, Time
- H = Heading, Attitude S = Sets, Stats, Quality

Message	Info Type	Max Output Rate	Description	IEC Approved Message
\$GPDTM	P	1 Hz	Datum reference	Yes
\$GPGGA	P	50 Hz	GPS position and fix data	Yes
\$GPGLL	P	50 Hz	Geographic position - lat/long	Yes
\$GPGNS	P	50 Hz	GNSS position and fix data	Yes
\$GPGRS	S	1 Hz	GNSS range residual (RAIM)	Yes
\$GPGSA	S	1 Hz	GNSS DOP and active satellites	Yes
\$GPGST	S	1 Hz	GNSS pseudo range error statistics and position accuracy	Yes
\$GPGSV	S	1 Hz	GNSS satellites in view	Yes
*\$GPHDG	H	50 Hz	Provides magnetic deviation and variation for calculating magnetic or true heading	Yes

Continued on next page

NMEA 0183 Messages, Continued

V200s
NMEA 0183 and
other
messages,
continued

Table C-2: NMEA 0183 and other messages (continued)

Message	Info Type	Max Output Rate	Description	IEC Approved Message
*\$GPHDM	H	50 Hz	Magnetic heading (based on GNSS-derived heading and magnetic declination)	No
*\$GPHDT	H	50 Hz	GNSS-derived true heading	Yes
\$GPHEV	H	50 Hz	Heave value (in meters)	Yes
\$GPRMC	P	50 Hz	Recommended minimum specific GNSS data	Yes
*\$GPROT	H	50 Hz	GNSS-derived rate of turn (ROT)	Yes
\$GPRRE	S	1 Hz	Range residual and estimated position error	Yes
\$GPVTG	V	50 Hz	COG and ground speed	Yes
\$GPZDA	V	50 Hz	Time and date	Yes
\$HEACK	S	1 Hz	Acknowledge alarm	Yes
\$HEACN	S	1 Hz	Alert command	Yes
\$HEALF	S	1 Hz	Alert sentence	Yes
\$HEALC	S	1 Hz	Cyclic alert list	Yes
\$HEALR	S	1 Hz	Set alarm state	Yes
\$HEHBT	S	1 Hz	Heartbeat supervision sentence	Yes

Continued on next page

NMEA 0183 Messages, Continued

V200s
NMEA 0183 and
other
messages,
 continued

Table C-2: NMEA 0183 and other messages (continued)

Message	Info Type	Max Output Rate	Description	IEC Approved Message
\$HETHS	H	50 Hz	True heading and status	Yes
\$PASHR	H	50 Hz	Time, heading, roll, and pitch data in one message	No
\$PSAT,GBS	S	1 Hz	Satellite fault detection (RAIM)	Yes
\$PSAT,HPR	H	50 Hz	Proprietary NMEA message that provides heading, pitch, roll, and time in single message	No
\$PSAT,INTLT	H	1 Hz	Proprietary NMEA message that provides the pitch and roll measurements from the internal inclinometers (in degrees)	Yes
\$RD1	S	1 Hz	SBAS diagnostic information	Yes
\$TSS1	H	50 Hz	Heading, pitch, roll, and heave message in the commonly used TSS1 message format	No

Continued on next page

NMEA 0183 Messages, Continued

Notes:

- The GP of the message is the talker ID
- You can change the message header for the HDG, HDM, HDT, and ROT messages to either GP or HE uses the \$JATT,NMEAHE command
 - To preface these messages with GP, issue the following command:
\$JATT,NMEAHE,0<CR><LF>
 - To preface these messages with HE, issue the following command:
\$JATT,NMEAHE,1<CR><LF>
- GPGRS, GPGSA, GPGST, and GPGSV support external integrity checking; synchronize with corresponding fix data (GPGGA or GPGNS)
- For information on outputting roll, pitch, and heave data in one message refer to the [Hemisphere GNSS Technical Reference Manual](#)
- HBT is sent every 30 seconds
- After 60 seconds, a heading loss warning is escalated to an alarm
- Silence timeout is 30 seconds
- THS message definition (from IEC61162-1 ed5): THS – True heading and status
- \$HETHS,x.x,a*hh<CR><LF>
- x.x Heading, degrees true
- a Mode indicator (This field should not be null): A = Autonomous, E = Estimated (dead reckoning), V = Data not valid (including standby)
- 50Hz output requires 50Hz-capable firmware plus 50Hz activation

For more information on the \$JATT,NMEAHE command refer to the [Hemisphere GNSS Technical Reference Manual](#).

Binary Messages

Binary messages

Table C-3 lists the Binary messages used by the V200s. To log raw binary data to convert to Rinex, turn on Bin 76 (GPS), Bin 66 (GLONASS), Bin 36 (BeiDou), **or** turn on Bin 16 (all constellations; required for Galileo).

Additionally, enable ephemeris messages: Bin 95 (GPS), Bin 65 (GLONASS), Bin 35 (BeiDou), and Bin 45 (Galileo).

Enable the time conversion messages: Bin 94 (GPS), Bin 34 (BeiDou), and Bin 44 (Galileo).

Table C-3: Binary messages

\$JBIN Message	Description
1	GNSS position
2	GPS DOPs
80	SBAS
93	SBAS ephemeris data
94	Ionosphere and UTC conversion parameters
95	Satellite ephemeris data
96	Code and carrier phase (not needed if using Bin 16, Bin 16 includes information for all constellations)
97	Processor statistics
98	Satellites and almanac
99	GPS diagnostics
16	All constellation code and phase observation data. Use Bin16 if you need Galileo code and carrier phase observation. Galileo does not have a separate message
34	BeiDou time conversion
35	BeiDou ephemeris information

Continued on next page

Binary Messages, Continued

Binary messages, continued

Table C-3: Binary messages (continued)

JBIN Message	Description
36	BeiDou code and carrier phase information (not needed if using Bin 16, Bin 16 includes information for all constellations)
44	Galileo time conversion
45	Galileo ephemeris
65	GLONASS ephemeris information
66	GLONASS code and carrier phase information (not needed if using Bin 16, Bin 16 includes information for all constellations)

Index

Activate Loader	21	Pitch	57, 65
Activation	6	Positioning accuracy	11
Atlas	6, 11, 48, 52	Positioning sustainability	11
beacon.....	50	Program Type	20
BeiDou.....	6	radar mounting plate	36
cable length.....	24	Rate-of-Turn.....	56
COAST.....	70	Rate-of-Turn (ROT).....	56, 57
Convergence time	11	RightArm	18
course-over-ground	56	RTCM.....	61, 63
Course-Over-Ground (COG)	57	RTK	7, 11, 48, 53, 55, 65
CSEP value.....	63	SBAS	7, 10, 48, 50, 51, 62, 65, 71, 75, 77
DGPS/DGNSS.....	6	Scalable service levels	11
Differential Corrections	6	Speed	57
environmental.....	24, 26	Subscription	6, 7
firmware.....	18, 19, 20, 21, 22	Tilt aiding.....	53
Firmware	18	tilt sensors.....	9, 53
GLONASS	6	TILTAID	63, 71
GPS	6, 7	VHF interference.....	25
gyro	54, 55, 56, 63, 70	VHF marine radio	25
HPR values	28	WebUI	18
NMEA	7		

End User License Agreement

End User license agreement

IMPORTANT - This is an agreement (the "**Agreement**") between you, the end purchaser ("**Licensee**") and Hemisphere GNSS Inc. ("**Hemisphere**") which permits Licensee to use the Hemisphere software (the "**Software**") that accompanies this Agreement. This Software may be licensed on a standalone basis or may be embedded in a Product. Please read and ensure that you understand this Agreement before installing or using the Software Update or using a Product.

In this agreement any product that has Software embedded in it at the time of sale to the Licensee shall be referred to as a "**Product**". As well, in this Agreement, the use of a Product shall be deemed to be use of the Software which is embedded in the Product.

BY INSTALLING OR USING THE SOFTWARE UPDATE OR THE PRODUCT, LICENSEE THEREBY AGREES TO BE LEGALLY BOUND BY THE TERMS OF THIS AGREEMENT. IF YOU DO NOT AGREE TO THESE TERMS, (I) DO NOT INSTALL OR USE THE SOFTWARE, AND (II) IF YOU ARE INSTALLING AN UPDATE TO THE SOFTWARE, DO NOT INSTALL THE UPDATE AND PROMPTLY DESTROY IT.

HEMISPHERE PROVIDES LIMITED WARRANTIES IN RELATION TO THE SOFTWARE. AS WELL, THOSE WHO USE THE EMBEDDED SOFTWARE DO SO AT THEIR OWN RISK. YOU SHOULD UNDERSTAND THE IMPORTANCE OF THESE AND OTHER LIMITATIONS SET OUT IN THIS AGREEMENT BEFORE INSTALLING OR USING THE SOFTWARE OR THE PRODUCT.

1. **LICENSE.** Hemisphere hereby grants to Licensee a non-transferable and non-exclusive license to use the Software as embedded in a Product and all Updates (collectively the "**Software**"), solely in binary executable form.
2. **RESTRICTIONS ON USE.** Licensee agrees that Licensee and its employees will not directly or indirectly, in any manner whatsoever:
 - a. install or use more copies of the Software than the number of copies that have been licensed;
 - b. use or install the Software in connection with any product other than the Product the Software was intended to be used or installed on as set out in the documentation that accompanies the Software.
 - c. copy any of the Software or any written materials for any purpose except as part of Licensee's normal backup processes;
 - d. modify or create derivative works based on the Software;
 - e. sub-license, rent, lease, loan or distribute the Software;
 - f. permit any third party to use the Software;
 - g. use or operate Product for the benefit of any third party in any type of service outsourcing, application service, provider service or service bureau capacity;
 - h. reverse engineer, decompile or disassemble the Software or otherwise reduce it to a human perceivable form;
 - i. Assign this Agreement or sell or otherwise transfer the Software to any other party except as part of the sale or transfer of the whole Product.
3. **UPDATES.** At Hemisphere's discretion Hemisphere may make Updates available to Licensee. An update ("**Update**") means any update to the Software that is made available to Licensee including error corrections, enhancements and other modifications. Licensee may access, download and install Updates during the Warranty Period only. All Updates that Licensee downloads, installs or uses shall be deemed to be Software and subject to this Agreement. Hemisphere reserves the right to modify the Product without any obligation to notify, supply or install any improvements or alterations to existing Software.
4. **SUPPORT.** Hemisphere may make available directly or through its authorized dealers telephone and email support for the Software. Contact Hemisphere to find the authorized dealer near you. As well, Hemisphere may make available user and technical documentation regarding the Software. Hemisphere reserves the right to reduce and limit access to such support at any time.

Continued on next page

End User License Agreement, Continued

End User license agreement, continued

5. **BACKUPS AND RECOVERY.** Licensee shall back-up all data used, created or stored by the Software on a regular basis as necessary to enable proper recovery of the data and related systems and processes in the event of a malfunction in the Software or any loss or corruption of data caused by the Software. Licensee shall assume all risks of loss or damage for any failure to comply with the foregoing.
6. **OWNERSHIP.** Hemisphere and its suppliers own all rights, title and interest in and to the Software and related materials, including all intellectual property rights. The Software is licensed to Licensee, not sold.
7. **TRADEMARKS.** Hemisphere GNSS[®], the Hemisphere GNSS logo, TRACER[™], Crescent[®], Eclipse[™], e-Dif[®], L-Dif[™], PocketMax[™], S320[™], SBX-4[™], Vector[™], Vega[™], Phantom[™] XF1[™], XF2[™], Cygnus[™], Atlas[™] aRTK, SureFix[™], Athena[™], Aquila[™], Lyra[™], Outback Guidance[™], and EDRIVE[™] are proprietary trademarks of Hemisphere GNSS, Inc. Other trademarks are the properties of their respective owners. and the associated logos are trademarks of Hemisphere. Other trademarks are the property of their respective owners. Licensee may not use any of these trademarks without the consent of their respective owners.
8. **LIMITED WARRANTY.** Hemisphere warrants solely to the Licensee, subject to the exclusions and procedures set forth herein below, that for a period of one (1) year from the original date of purchase of the Product in which it is embedded (the "Warranty Period"), the Software, under normal use and maintenance, will conform in all material respects to the documentation provided with the Software and any media will be free of defects in materials and workmanship. For any Update, Hemisphere warrants, for 90 days from performance or delivery, or for the balance of the original Warranty Period, whichever is greater, that the Update, under normal use and maintenance, will conform in all material respects to the documentation provided with the Update and any media will be free of defects in materials and workmanship. Notwithstanding the foregoing, Hemisphere does not warrant that the Software will meet Licensee's requirements or that its operation will be error free.
9. **WARRANTY EXCLUSIONS.** The warranty set forth in Section (8) will not apply to any deficiencies caused by (a) the Product not being used as described in the documentation supplied to Licensee, (b) the Software having been altered, modified or converted in any way by anyone other than Hemisphere approved by Hemisphere, (c) any malfunction of Licensee's equipment or other software, or (d) damage occurring in transit or due to any accident, abuse, misuse, improper installation, lightning (or other electrical discharge) or neglect other than that caused by Hemisphere. Hemisphere GNSS does not warrant or guarantee the precision or accuracy of positions obtained when using the Software (whether standalone or embedded in a Product). The Product and the Software is not intended and should not be used as the primary means of navigation or for use in safety of life applications. The potential positioning and navigation accuracy obtainable with the Software as stated in the Product or Software documentation serves to provide only an estimate of achievable accuracy based on specifications provided by the US Department of Defense for GPS positioning and DGPS service provider performance specifications, where applicable.
10. **WARRANTY DISCLAIMER.** EXCEPT AS EXPRESSLY SET OUT IN THIS AGREEMENT, HEMISPHERE MAKES NO REPRESENTATION, WARRANTY OR CONDITION OF ANY KIND TO LICENSEE, WHETHER VERBAL OR WRITTEN AND HEREBY DISCLAIMS ALL REPRESENTATIONS, WARRANTIES AND CONDITIONS OF ANY KIND INCLUDING FITNESS FOR A PARTICULAR PURPOSE, MERCHANTABILITY, ACCURACY, RELIABILITY OR THAT THE USE OF THE SOFTWARE WILL BE UNINTERRUPTED OR ERROR-FREE AND HEREBY DISCLAIMS ALL REPRESENTATIONS, WARRANTIES AND CONDITIONS ARISING AS A RESULT OF CUSTOM, USAGE OR TRADE AND THOSE ARISING UNDER STATUTE.
11. **LIMITS ON WARRANTY DISCLAIMER.** Some jurisdictions do not allow the exclusion of implied warranties or conditions, so some of the above exclusions may not apply to Licensee. In that case, any implied warranties or conditions which would then otherwise arise will be limited in duration to ninety (90) days from the date of the license of the Software or the purchase of the Product. The warranties given herein give Licensee specific legal rights and Licensee may have other rights which may vary from jurisdiction to jurisdiction.

Continued on next page

End User License Agreement, Continued

End User license agreement, continued

12. **CHANGE TO WARRANTY.** No employee or agent of Hemisphere is authorized to change the warranty provided or the limitation or disclaimer of warranty provisions. All such changes will only be effective if pursuant to a separate agreement signed by senior officers of the respective parties.
13. **WARRANTY CLAIM.** In the event Licensee has a warranty claim Licensee must first check for and install all Updates that are made available. The warranty will not otherwise be honored. Proof of purchase may be required. Hemisphere does not honor claims asserted after the end of the Warranty Period.
14. **LICENSEE REMEDIES.** In all cases which involve a failure of the Software to conform in any material respect to the documentation during the Warranty Period or a breach of a warranty, Hemisphere's sole obligation and liability, and Licensee's sole and exclusive remedy, is for Hemisphere, at Hemisphere's option, to (a) repair the Software, (b) replace the Software with software conforming to the documentation, or (c) if Hemisphere is unable, on a reasonable commercial basis, to repair the Software or to replace the Software with conforming software within ninety (90) days, to terminate this Agreement and thereafter Licensee shall cease using the Software. Hemisphere will also issue a refund for the price paid by Licensee less an amount on account of amortization, calculated on a straight-line basis over a deemed useful life of three (3) years.
15. **LIMITATION OF LIABILITY.** IN NO EVENT WILL HEMISPHERE BE LIABLE TO LICENSEE FOR ANY INCIDENTAL, CONSEQUENTIAL, SPECIAL OR INDIRECT DAMAGES INCLUDING ARISING IN RELATION TO ANY LOSS OF DATA, INCOME, REVENUE, GOODWILL OR ANTICIPATED SAVINGS EVEN IF HEMISPHERE HAS BEEN INFORMED OF THE POSSIBILITY OF SUCH LOSS OR DAMAGE. FURTHER, IN NO EVENT WILL HEMISPHERE'S TOTAL CUMULATIVE LIABILITY HEREUNDER, FROM ALL CAUSES OF ACTION OF ANY KIND, EXCEED THE TOTAL AMOUNT PAID BY LICENSEE TO HEMISPHERE TO PURCHASE THE PRODUCT. THIS LIMITATION AND EXCLUSION APPLIES IRRESPECTIVE OF THE CAUSE OF ACTION, INCLUDING BUT NOT LIMITED TO BREACH OF CONTRACT, NEGLIGENCE, STRICT LIABILITY, TORT, BREACH OF WARRANTY, MISREPRESENTATION OR ANY OTHER LEGAL THEORY AND WILL SURVIVE A FUNDAMENTAL BREACH.
16. **LIMITS ON LIMITATION OF LIABILITY.** Some jurisdictions do not allow for the limitation or exclusion of liability for incidental or consequential damages, so the above limitation or exclusion may not apply to Licensee and Licensee may also have other legal rights which may vary from jurisdiction to jurisdiction.
17. **BASIS OF BARGAIN.** Licensee agrees and acknowledges that Hemisphere has set its prices and the parties have entered into this Agreement in reliance on the limited warranties, warranty disclaimers and limitations of liability set forth herein, that the same reflect an agreed-to allocation of risk between the parties (including the risk that a remedy may fail of its essential purpose and cause consequential loss), and that the same forms an essential basis of the bargain between the parties. Licensee agrees and acknowledges that Hemisphere would not have been able to sell the Product at the amount charged on an economic basis without such limitations.
18. **PROPRIETARY RIGHTS INDEMNITY.** Hemisphere shall indemnify, defend and hold harmless Licensee from and against any and all actions, claims, demands, proceedings, liabilities, direct damages, judgments, settlements, fines, penalties, costs and expenses, including royalties and attorneys' fees and related costs, in connection with or arising out of any actual infringement of any third party patent, copyright or other intellectual property right by the Software or by its use, in accordance with this Agreement and documentation, PROVIDED THAT: (a) Hemisphere has the right to assume full control over any action, claim, demand or proceeding, (b) Licensee shall promptly notify Hemisphere of any such action, claim, demand, or proceeding, and (c) Licensee shall give Hemisphere such reasonable assistance and tangible material as is reasonably available to Licensee for the defense of the action, claim, demand or proceeding. Licensee shall not settle or compromise any of same for which Hemisphere has agreed to assume responsibility without Hemisphere's prior written consent. Licensee may, at its sole cost and expense, retain separate counsel from the counsel utilized or retained by Hemisphere. 19. **INFRINGEMENT.** If use of the Software may be enjoined due to a claim of infringement by a third party then, at its sole discretion and expense, Hemisphere may do one of the following: (a)

Continued on next page

End User License Agreement, Continued

End User license agreement, continued

19. negotiate a license or other agreement so that the Product is no longer subject to such a potential claim, (b) modify the Product so that it becomes non-infringing, provided such modification can be accomplished without materially affecting the performance and functionality of the Product, (c) replace the Software, or the Product, with non-infringing software, or product, of equal or better performance and quality, or (d) if none of the foregoing can be done on a commercially reasonable basis, terminate this license and Licensee shall stop using the Product and Hemisphere shall refund the price paid by Licensee less an amount on account of amortization, calculated on a straight-line basis over a deemed useful life of three (3) years.
20. The foregoing sets out the entire liability of Hemisphere and the sole obligations of Hemisphere to Licensee in respect of any claim that the Software or its use infringes any third party rights.
21. **INDEMNIFICATION.** Except in relation to an infringement action, Licensee shall indemnify and hold Hemisphere harmless from any and all claims, damages, losses, liabilities, costs and expenses (including reasonable fees of lawyers and other professionals) arising out of or in connection with Licensee's use of the Product, whether direct or indirect, including without limiting the foregoing, loss of data, loss of profit or business interruption. **TERMINATION.** Licensee may terminate this Agreement at any time without cause. Hemisphere may terminate this Agreement on 30 days notice to Licensee if Licensee fails to materially comply with each provision of this Agreement unless such default is cured within the 30 days. Any such termination by a party shall be in addition to and without prejudice to such rights and remedies as may be available, including injunction and other equitable remedies. Upon receipt by Licensee of written notice of termination from Hemisphere or termination by Licensee, Licensee shall at the end of any notice period (a) cease using the Software; and (b) return to Hemisphere (or destroy and provide a certificate of a Senior Officer attesting to such destruction) the Software and all related material and any magnetic or optical media provided to Licensee. The provisions of Sections 6), 7), 8), 9), 10), 15), 21), 26) and 27) herein shall survive the expiration or termination of this Agreement for any reason.
22. **EXPORT RESTRICTIONS.** Licensee agrees that Licensee will comply with all export control legislation of Canada, the United States, Australia and any other applicable country's laws and regulations, whether under the Arms Export Control Act, the International Traffic in Arms Regulations, the Export Administration Regulations, the regulations of the United States Departments of Commerce, State, and Treasury, or otherwise as well as the export control legislation of all other countries.
23. **PRODUCT COMPONENTS.** The Product may contain third party components. Those third party components may be subject to additional terms and conditions. Licensee is required to agree to those terms and conditions in order to use the Product.
24. **FORCE MAJEURE EVENT.** Neither party will have the right to claim damages as a result of the other's inability to perform or any delay in performance due to unforeseeable circumstances beyond its reasonable control, such as labor disputes, strikes, lockouts, war, riot, insurrection, epidemic, Internet virus attack, Internet failure, supplier failure, act of God, or governmental action not the fault of the non-performing party.
25. **FORUM FOR DISPUTES.** The parties agree that the courts located in Calgary, Alberta, Canada and the courts of appeal there from will have exclusive jurisdiction to resolve any disputes between Licensee and Hemisphere concerning this Agreement or Licensee's use or inability to use the Software and the parties hereby irrevocably agree to attorn to the jurisdiction of those courts. Notwithstanding the foregoing, either party may apply to any court of competent jurisdiction for injunctive relief.
26. **APPLICABLE LAW.** This Agreement shall be governed by the laws of the Province of Alberta, Canada, exclusive of any of its choice of law and conflicts of law jurisprudence.
27. **CISG.** The United Nations Convention on Contracts for the International Sale of Goods will not apply to this Agreement or any transaction hereunder.

GENERAL. This is the entire agreement between Licensee and Hemisphere relating to the Product and Licensee's use of the same, and supersedes all prior, collateral or contemporaneous oral or written representations, warranties or agreements regarding the same. No amendment to or modification of this Agreement will be binding unless in writing and signed by duly authorized representatives of the parties. Any and all terms and conditions set out in any correspondence between the parties or set out in a purchase order which are different from or in addition to the terms and conditions set forth herein, shall have no application and no written notice of same shall be required. In the event that one or more of the provisions of this Agreement is found to be illegal or unenforceable, this Agreement shall not be rendered inoperative but the remaining provisions shall continue in full force and effect.

Warranty Notice

Warranty notice

COVERED PRODUCTS: This warranty covers all products manufactured by Hemisphere GNSS and purchased by the end purchaser (the "Products"), unless otherwise specifically and expressly agreed in writing by Hemisphere GNSS.

LIMITED WARRANTY: Hemisphere GNSS warrants solely to the end purchaser of the Products, subject to the exclusions and procedures set forth below, that the Products sold to such end purchaser and its internal components shall be free, under normal use and maintenance, from defects in materials, and workmanship and will substantially conform to Hemisphere GNSS's applicable specifications for the Product, for a period of 12 months from delivery of such Product to such end purchaser (the "Warranty Period"). Repairs and replacement components for the Products are warranted, subject to the exclusions and procedures set forth below, to be free, under normal use and maintenance, from defects in material and workmanship, and will substantially conform to Hemisphere GNSS's applicable specifications for the Product, for 90 days from performance or delivery, or for the balance of the original Warranty Period, whichever is greater.

EXCLUSION OF ALL OTHER WARRANTIES. The LIMITED WARRANTY shall apply only if the Product is properly and correctly installed, configured, interfaced, maintained, stored, and operated in accordance with Hemisphere GNSS relevant User's Manual and Specifications, AND the Product is not modified or misused. The Product is provided "AS IS" and the implied warranties of MERCHANTABILITY and FITNESS FOR A PARTICULAR PURPOSE and ALL OTHER WARRANTIES,

express, implied or arising by statute, by course of dealing or by trade usage, in connection with the design, sale, installation, service or use of any products or any component thereof, are EXCLUDED from this transaction and shall not apply to the Product. The LIMITED WARRANTY is IN LIEU OF any other warranty, express or implied, including but not limited to, any warranty of MERCHANTABILITY or FITNESS FOR A PARTICULAR PURPOSE, title, and non-infringement.

LIMITATION OF REMEDIES. The purchaser's EXCLUSIVE REMEDY against Hemisphere GNSS shall be, at Hemisphere GNSS's option, the repair or replacement of any defective Product or components thereof. The purchaser shall notify Hemisphere GNSS or a Hemisphere GNSS's approved service center immediately of any defect. Repairs shall be made through a Hemisphere GNSS approved service center only. Repair, modification or service of Hemisphere GNSS products by any party other than a Hemisphere GNSS approved service center shall render this warranty null and void. The remedy in this paragraph shall only be applied in the event that the Product is properly and correctly installed, configured, interfaced, maintained, stored, and operated in accordance with Hemisphere GNSS's relevant User's Manual and Specifications, AND the Product is not modified or misused. NO OTHER REMEDY (INCLUDING, BUT NOT LIMITED TO, SPECIAL, INDIRECT, INCIDENTAL, CONSEQUENTIAL OR CONTINGENT DAMAGES FOR LOST PROFITS, LOST SALES, INJURY TO PERSON OR PROPERTY, OR ANY OTHER INCIDENTAL OR CONSEQUENTIAL LOSS) SHALL BE AVAILABLE

TO PURCHASER, even if Hemisphere GNSS has been advised of the possibility of such damages. Without limiting the foregoing, Hemisphere GNSS shall not be liable for any damages of any kind resulting from installation, use, quality, performance or accuracy of any Product.

HEMISPHERE IS NOT RESPONSIBLE FOR PURCHASER'S NEGLIGENCE OR UNAUTHORIZED USES OF THE PRODUCT.

IN NO EVENT SHALL Hemisphere GNSS BE IN ANY WAY RESPONSIBLE FOR ANY DAMAGES RESULTING FROM PURCHASER'S OWN NEGLIGENCE, OR FROM OPERATION OF THE PRODUCT IN ANY WAY OTHER THAN AS SPECIFIED IN Hemisphere GNSS's RELEVANT USER'S MANUAL AND SPECIFICATIONS. Hemisphere GNSS is NOT RESPONSIBLE for defects or performance problems resulting from (1) misuse, abuse, improper installation, neglect of Product; (2) the utilization of the Product with hardware or software products, information, data, systems, interfaces or devices not made, supplied or specified by Hemisphere GNSS; (3) the operation of the Product under any specification other than, or in addition to, the specifications set forth in Hemisphere GNSS's relevant User's Manual and Specifications; (4) damage caused by accident or natural events, such as lightning (or other electrical discharge) or fresh/ salt water immersion of Product; (5) damage occurring in transit; (6) normal wear and tear; or (7) the operation or failure of operation of any satellite-based positioning system or differential correction service; or the availability or performance of any satellite-based positioning signal or differential correction signal.

THE PURCHASER IS RESPONSIBLE FOR OPERATING THE VEHICLE SAFELY. The purchaser is solely responsible for the safe operation of the vehicle used in connection with the Product, and for maintaining proper system control settings. UNSAFE DRIVING OR SYSTEM CONTROL SETTINGS CAN RESULT IN PROPERTY DAMAGE, INJURY, OR DEATH.

Continued on next page

Warranty Notice, Continued

Warranty notice, continued

The purchaser is solely responsible for his/her safety and for the safety of others. The purchaser is solely responsible for maintaining control of the automated steering system at all times. THE PURCHASER IS SOLELY RESPONSIBLE FOR ENSURING THE PRODUCT IS PROPERLY AND CORRECTLY INSTALLED, CONFIGURED, INTERFACED, MAINTAINED, STORED, AND OPERATED IN ACCORDANCE WITH Hemisphere GNSS's RELEVANT USER'S MANUAL AND SPECIFICATIONS. Hemisphere GNSS does not warrant or guarantee the positioning and navigation precision or accuracy obtained when using Products. Products are not intended for primary navigation or for use in safety of life applications. The potential accuracy of Products as stated in Hemisphere GNSS literature and/or Product specifications serves to provide only an estimate of achievable accuracy based on performance specifications provided by the satellite service operator (i.e. US Department of Defense in the case of GPS and differential correction service provider. Hemisphere GNSS reserves the right to modify Products without any obligation to notify, supply or install any improvements or alterations to existing Products.

GOVERNING LAW. This agreement and any disputes relating to, concerning or based upon the Product shall be governed by and interpreted in accordance with the laws of the State of Arizona.

OBTAINING WARRANTY SERVICE. In order to obtain warranty service, the end purchaser must bring the Product to a Hemisphere GNSS approved service center along with the end purchaser's proof of purchase. Hemisphere GNSS does not warrant claims asserted after the end of the warranty period. For any questions regarding warranty service or to obtain information regarding the location of any of Hemisphere GNSS approved service center, contact Hemisphere GNSS at the following address:

Hemisphere GNSS

8515 E. Anderson Drive Scottsdale, AZ 85255, USA

Phone: +1-480-348-6380

Fax: +1-480-270-5070

TECHSUPPORT@HGSS.COM

WWW.HGSS.COM



Hemisphere GNSS Inc.
8515 East Anderson Drive
Scottsdale, Arizona, US 85255
Phone: 480-348-6380
Fax: 480-270-5070
PRECISION@HGNSS.COM
WWW.HGNSS.COM